

WISE Journal

*The official journal of the World Institute for
Scientific Exploration (WISE)*

Volume 4, No. 3 (Fall, 2015)

The Journal of the World Institute for Scientific Exploration

Editorial Office: WISE Journal, World Institute for Scientific Exploration (WISE), John H. Reed, M.D., Managing Editor, 4401 Roland Avenue, Suite 405, Baltimore, MD 21210, USA. Email: joreed43@gmail.com; telephone: 443-858-0575

Manuscript Submission: Submit all manuscripts as Microsoft Word documents only. The text of the manuscripts may be in any language, including Chinese, Japanese, Hindi, and other non-Roman alphabetic languages.

Editor-in-Chief: Dr. Dominique Surel
Managing Editor: John H. Reed, M.D.
Associate Editor: Richard Blasband, M.D.
Chinese Editor: Yunqiu (Rachel) Wang

WISE Board of Distinguished Scientific Advisors

William Bengston, Ph.D., St. Joseph' College, Patchogue, New York;
Larissa Cheran, Ph.D., University of Toronto, Toronto, Canada, and formerly Institute of Microtechnologies, Bucharest, Romania;
Larry Dossey, M.D., Distinguished physician, author, and editor of Explore Journal, Santa Fe, New Mexico;
Richartha Gundlapalli, M.D., FAAP, Integrative Physician, DABSEM Specialist
Vijay K. Gupta, Ph.D., University of Colorado, Boulder, Colorado; World Community Service Center (WCSC), Chennai, Tamil Nadu, India;
Judith Hedje, M.D., MPH, MBA, National Institutes of Health, Bethesda, Maryland;
Yury Kronn, Ph.D., Energy Tools International, Eagle Point, Oregon; and formerly Russian Academy of Sciences, Moscow, Russia;
Shanmugamurthy Lakshmanan, Ph.D., MS, MSc., Harvard University, Cambridge, Massachusetts; and International Institute of Human Excellence, Chennai, Tamil Nadu, India;
Lynhiavu LySao, M.D., Distinguished Surgeon, Chief of Surgery, Hopital de l'Amitie, Vientiane, Laos;
Vernon M. Neppe, M.D., Ph.D., FRSSAf, DFAPA, Director, Pacific Neuropsychiatric Institute, Seattle, Washington;
Robert Patterson, Ph.D., University of Minnesota, Minneapolis, Minnesota;
Stoyan Sarg Sargoytchev, Ph.D., York University, Toronto, Canada; and formerly Central Laboratory for Space Sciences, Bulgaria Academy of Sciences, Sofia, Bulgaria;
Albert So, Ph.D., University of Hong Kong, Hong Kong, China;
David E. Stein, Lt Col, USAF (Ret), physicist and futurist;
Jean-Christophe Terrillon, Ph.D., Japan Advanced Institute of Science and Technology, Ishikawa, Japan;
Leonard A. Wisneski, M.D., FACP, University of Colorado, Medical Campus, Denver, CO; George Washington University Medical Center, Washington, DC; and Georgetown University, Washington, DC;

World Institute for Scientific Exploration (WISE) website: <http://instituteforscientificexploration.org>

WISE Resource Center & Online Library: [//wisewiki.org](http://wisewiki.org)

Back Issues in full text of all issues of WISE Journal and its predecessor, WISE Newsletter, are available in the [WISE Digital Library at this link](#).

Copyright: Authors retain the copyright to their writings. However, WISE has the right to post issues of the WISE Journal and WISE Newsletter in the WISE Digital Library and elsewhere on the Internet.

WISE Journal (ISSN: Pending) is published quarterly in the Spring, Summer, Fall, and Winter by the World Institute for Scientific Exploration (WISE), 4401 Roland Avenue, Suite 405, Baltimore, MD, 21210 USA.

Dear Colleagues,

In this issues, we have a number of very interesting articles by well known researchers. As you will see below, we have changed the order of the Table of Contents, whereby we are putting the research articles first, followed by the News and Events section and then the Book Reviews. Because of the importance of the research being conducted, we thought that such articles should appear in the first section rather than last. Just scroll down to the Table of Contents to see the article titles, and then scroll down further to read all of the exciting news.

WISE provides a research institute and a worldwide internet platform for the dissemination of information and research on scientific anomalies, alternative, complementary, and traditional medicine, consciousness, parapsychology, alternative energy, paranormal topics, historical legends, and unexplained phenomena of all kinds. This is accomplished through our many programs, especially the [WISE Worldwide Resource Center \(WISEwiki\)](#) and the [WISE Digital Library](#). We seek to maximize research collaboration and cooperation on these subjects, and WISE wants to make sure that we include all individuals, worldwide, who would like to participate in the our programs and activities, and not have membership dues or the lack of money to be an inhibiting factor.

Remember that WISE has eliminated all membership fees and dues, but yet provides more programs and benefits than any other organization in this field. ([Click here to go to the page showing the seventeen \(17\) benefits you will enjoy as a member and research associate of this institute.](#)) Instead of dues, we encourage you to become active in our programs and projects, and contribute your passion and knowledge, as many of you are already doing.

As usual, people are joining WISE from all over the world, and more members are volunteering to help with and start research projects, to become division, department, or national advisers, and to offer other support for our great quest to do research on the above subjects. **We now have over 10,000 members and research associates from more than 60 countries worldwide.**

We Thank You all for being part of WISE, and wish you success in all of your research and other projects in 2015.

John H. Reed, M.D., Dominique Surel, Ph.D., Richard Blasband, M.D.

Table of Contents

Articles:

Interpreting Science Through Feasibility and Replicability: Extending the Scientific Method by Applying “Lower Dimensional Feasibility, Absent Falsification” (LFAF) , by Vernon M. Neppe MD, PhD, FRSSAf, DFAPA and Edward R. Close PhD, PE p. 3

Change of Strategy in Cancer Care Management: Cancer Immunotherapy a Major Breakthrough Leading to a Paradigm Shift, by Gaston Naessens, ND (Naturopathic Doctor) Jacinte Levesque Naessens, B.S., B.E., M.S., TCMD p. 38

THE STRUCTURE OF WATER and HOW PSYCHE ENTERS MATTER by Dr. Richard Alan Miller p. 44

ELECTROPHOTONIC ANALYSIS OF COMPLEX PARAMETERS OF THE ENVIRONMENT AND PSYCHO-EMOTIONAL STATE OF A PERSON, by Dr. Konstantin G. Korotkov p. 49

Living Organisms and Structures in the Physical Vacuum by Nina Sotina, Ph.D. p. 57

Why the Last Century’s Quantum Mechanics (QM) is Irrelevant in a Duplex, Reciprocal Subspace, Reference Frame for Our Cognitive World, by William A Tiller, Ph.D. and Walter E. Dibble, Jr., Ph.D. p. 65

The Mystery Megaliths of Colombia, by David Hatcher Childress p. 93

The Zen Is Mightier Than the Sword, by Dennis Stillings p. 104

News and Events:

WISE Adds 25 More Full-Text Periodical Titles to Its Digital Library, Total Now at 307 p. 106

WISE-Hong Kong Inaugural Opening Event – Great Success! p. 115

Books of Importance:

Crimes of Reason – On Mind, Nature, and the Paranormal, by Steven E. Braude p. 117

ESP Induction Through Forms of Self-Hypnosis, by Richard Alan Miller, Ph.D. p. 118

Atlin – Knowing I Am, by Dale Pond p. 119

[Interesting Advertisements](#) (new book, T. Townsend Brown's Papers, Smithsonian Secret Warehouse, and others) ([Special: William R. Corliss Books for sale](#))

Interpreting science through feasibility and replicability: Extending the scientific method by applying “Lower Dimensional Feasibility, Absent Falsification” (LFAF)

Vernon M. Neppe MD, PhD, FRSSAf, DFAPA ^a and Edward R. Close PhD, PE ^{b c}

Abstract: ^d

In this paper, we re-visit and amplify the philosophy of science concept of “Lower Dimensional Feasibility, Absent Falsification (LFAF)” originally proposed by Neppe and Close in 2012. ¹ LFAF is pertinent because it extends scientific thinking beyond Popperian falsifiability ² by including feasibility as another level of proof. We show how LFAF can be applied to nine different areas of science namely:

- 1. the scientific method;*
- 2. the philosophy of science approach with the addition of feasibility making scientific evaluation more versatile;*
- 3. the critical role of mathematics in science; including whether mathematics is simply required for calculations or an essential part of reality;*
- 4. the need to expand mathematical logic;*
- 5. the need to amplify the logic of scientific data approaches;*
- 6. recognizing that exact replicability is almost impossible except in the harder physical sciences where minimal confounding factors don't matter;*
- 7. re-evaluating the fundamental concepts of science and how critical the LFAF concept is;*
- 8. analyzing the nature of creativity and of reality, including using the model of TDVP ^e;*
- 9. the extension of the concept of science by applying LFAF: This includes feasibility.*

LFAF has key applications across the sciences. This is particularly so in two disciplines:

A. the practice of Medicine in which:

- the feasibility of diagnoses is extremely important, and often bidirectional inferences are applied; and*
- the prescriptions of treatment are usually based on unstated feasibility measures of*

^a Vernon M. Neppe, Director, Pacific Neuropsychiatric Institute, Seattle, WA; Distinguished Professor, Exceptional Achievement Organization; and Adj. Prof., Department of Neurology and Psychiatry, St Louis University, St Louis, MO; Director, Human Performance Enhancement Division (HPED) of the World Institute of Scientific Exploration (WISE).

^b Edward R. Close. Research Associate, Pacific Neuropsychiatric Institute, Seattle, WA; and Distinguished Fellow, Exceptional Creative Achievement Organization.

^c © Brainvoyage.com 2012.

^d The “LFAF” concept was originally described in our book *Reality begins with consciousness: a paradigm shift that works (1st Edition)* ¹.

^e TDVP: ^{3;4} The Triadic Dimensional-Distinction Vortical Paradigm is a metaparadigmatic model developed equally by Drs. Vernon Neppe and Edward Close. It is based on the available broader empirical data of all the sciences (physical, biological, consciousness and psychological), validated partly by mathematical theorems, applying LFAF for scientific validation, and applied to philosophy (as “Unified Monism”). The key features are tethering of Space, Time and broader “Consciousness (STC), nine finite discrete dimensions and further transfinite discrete dimensions all embedded within a “continuous infinity”. TDVP allows for a model of life that always *exists* in the infinite, and an infinite order translated in the finite into multidimensional order.

patient response without sufficient side-effects: These characteristics ensure the best clinical measures of efficacious outcome (irrespective of whether statistical results have demonstrated falsifiable data). And in:

B. *Dimensional Biopsychophysics, a discipline in which the multidimensional perspective is extraordinarily important. Applying LFAF allows for the scientific empirical, inductive and mathematical studies of extra dimensions. This is critically important because the concept of extra dimensions is no longer only theoretical because mathematically the 9 dimensional spin model has been derived and demonstrated by several calculations and is replicable^{5; 6; 7; 8; 9}. Such LFAF studies can apparently also now include the relatively non-local^{8; 10; 11; 17; 12}, psi¹², explorations of altered states of consciousness, the covert happenings that may be affecting our day-to-day reality, and models for “theories of everything”. Without including the addition of feasibility, these advances would not be possible.*

We also introduce a new model for consideration, the 11 Neppe-Close Revolutions (11NCR): This necessarily extends Kuhn’s various stages of understandings of the revolutions¹³ of change—the reshaping of science—by adding several more paths along the eleven key periods of adjustment.

‘Let us suppose that an ichthyologist is exploring the life of the ocean. He casts a net into the water and brings up a fishy assortment. Surveying his catch, he proceeds in the usual manner of a scientist to systematize what it reveals. He arrives at two generalizations:

- (1) No sea-creature is less than two inches long.*
- (2) All sea-creatures have gills.*

These are both true of his catch, and he assumes tentatively that they will remain true however often he repeats it.’

‘In applying this analogy, the catch stands for the body of knowledge which constitutes physical science, and the net for the sensory and intellectual equipment which we use in obtaining it. The casting of the net corresponds to observation: for knowledge which has not been or could not be obtained by observation is not admitted into physical science. An

onlooker may object that the first generalization is wrong. “There are plenty of sea-creatures under two inches long, only your net is not adapted to catch them.”

The ichthyologist dismisses this objection contemptuously. “Anything uncatchable by my net is ipso facto outside the scope of ichthyological knowledge.” In short, “What my net can't catch isn't fish.” Or — to translate the analogy — “If you are not simply guessing, you are claiming a knowledge of the physical universe discovered in some other way than by the methods of physical science, and admittedly unverifiable by such methods.

You are a metaphysician. Bah!”

“The mathematics is not there till we put it there.”’

Sir Arthur Eddington, 1938^{14 f}

^f Sir Arthur Eddington (1882 - 1944), the great British Astrophysicist and Philosopher of Science, quoted from Eddington’s book *The Philosophy of Physical Science* in 1938¹⁴. Eddington became world-famous when his observations on 29 May 1919 of the bending of starlight near the eclipsed sun confirmed predictions made by Albert Einstein in his General Theory of Relativity.

Sir Arthur Eddington's remarkable insight that obvious experimental data may not locate all of reality reflects an understanding that, at times, our approach to what we regard as science is limited. We cannot appreciate all of reality when only applying a small component of reality. And our approach to science is clearly linked with our perception of reality.

Therefore, we must examine whether:

- the Scientific Methodological Approach has some limitations and needs additions;
- the Philosophy of Science Approach must be amplified;
- specifically feasibility would make such Philosophy of Science approaches more versatile;
- there is a critical role for mathematics in science;
- the axiomatic basis of mathematical logic must be expanded;
- amplifications of logical scientific data approaches;
- replicability is a key issue in science;
- the fundamental concepts of science should be re-examined;
- lower dimensional feasibility, absent falsification (LFAF) is critical;
- the need for LFAF in the Neppe-Close Triadic Dimensional Distinction Vortical Paradigm (TDVP) ^{15; 16; 17; 18.};
- we can analyze the nature of reality;
- we can apply a summation for what science is all about.

In short, the answers to all these items are “indeed, we must expand and amplify these areas”. A common theme to all twelve of these issues involves considering what is feasible, as well as what is falsifiable and what is replicable. This is why in this paper we emphasize our proposed new concept of “lower dimensional feasibility, absent falsification”.

Key concepts

We're dealing with several concepts in the Philosophy of Science. Consequently, we apply some key concepts in the sections that follow, Issues 1 through 12.

We supply, too, tabulated prioritizations of where these scientific notions fit, what constitutes science, and what may need to be expanded to encompass what is now known.

These Tables are married with data in the text.

Issue 1: The classical scientific approach and its limitations

We begin with understanding what is known and what is not known.

- In Table 1A, we tabulate the *general scientific approach* that is *conventionally* used, based on the consensus approach of what is known. This *approach* to science may reflect

a legitimate way to conceptualize science that has been well-tried and tested over centuries.

- We then test ideas to establish if we can extend what is known, or at least, if we can replicate what is known. We frequently apply statistical approaches to ensure that the hypotheses are appropriately tested.
- At the next level, we ensure that our methodology to test our ideas is appropriate. This involves careful planning, not only of our sample and sample sizes and its generalization to the appropriate population, but application of appropriate techniques to ensure the research method we've applied is legitimate.
- We then analyze our results appropriately, applying the pre-defined techniques we had listed in our hypotheses. From there, we're able to discuss our results, recognize limitations and strengths and arrive at conclusions. In this approach, we emphasize what is falsifiable and what is potentially replicable.

Table 1A: General scientific approach and the place of feasibility

Literature review	
<i>What is known:</i>	• <u>This includes current consensus opinions.</u>
<i>Limitations:</i>	• Limits are at times unnamed as not stipulated.
Hypotheses and ideas	
<i>Statistical and non-statistical hypotheses</i>	<ul style="list-style-type: none"> • <i>Stipulated statistical analyses</i> • <i>Non-statistical “unproven” components amplified</i> • <i>Induction techniques</i>
Methodology	<ul style="list-style-type: none"> • <i>Samples and comparisons</i> • <i>Key controls</i> • <i>Evaluation tests applied</i> • <i>Data collection</i> <ul style="list-style-type: none"> ○ <i>Statistical analytic techniques</i> ○ <i>Non-statistical analysis</i> • <i>Uncontrolled data and confounding factors</i>
Results	<ul style="list-style-type: none"> • <i>Statistical analyses based on falsifiability</i> • <i>Non-statistical pertinence: Sometimes neglected but often inductive methods involve observations that are not statistical</i>
Discussion	<ul style="list-style-type: none"> • <i>Strengths</i> • <i>Weaknesses</i>
Conclusions	<ul style="list-style-type: none"> • <i>Generalizations from the specific data to the general</i> • <i>Replications</i> • <i>Further ideas generated.</i>

The solutions to extending this scientific approach are then added in Table 1B.

- Before rejecting data as unscientific because it may not be *falsifiable*, we need to apply *feasibility* as the next stage.

- Even more so, if something is falsifiable but has not been falsified, feasibility can amplify data (as in Medicine). Under those circumstances, feasibility often makes the results more practically useful.
- The higher the level of scientific proof, the better. We argue that mathematical proof is the highest level of scientific proof because it does not rely on frequentist or Bayesian statistical arguments.^{12 8}
- The axiomatic basis of mathematics may have to be clarified and expanded to accommodate new empirical knowledge about the nature of reality.

In Table 1B, the current scientific approach (that is listed in Table 1A) is amplified. The major additions pertain to feasibility of the hypotheses and outcome. By adding in extra pieces into the “jigsaw puzzle” of what is realizable, this procedure allows for extending our boundaries of knowledge, and for creativity and originality. Such a technique is critical, *inter alia* (we will see), when applying multidimensional models.

This way we do not avoid excluding data that might be incorrectly considered as irrelevant, when more appropriately it would be labeled as feasible. The inclusion of feasibility considerations allows for what might be critical conceptual jumps to other dimensions, and for expansions of scientific theory based on new information.

Table 1B: Specifically the additions to the classical scientific approach (added to Table 1A)

Hypotheses and ideas	<ul style="list-style-type: none"> • Mathematical proofs and logic. <i>Mathematics and logic are keys to further understanding of science. This is, at times, appreciated; but sometimes it is not.</i> It is generally assumed by most scientists that mathematical logic as it is currently understood, is complete. Gödel’s incompleteness theorems prove that this is an error.^{19; 20} • What is feasible? Feasibility till now has been neglected, yet, we argue, it is a key to the scientific method. Often the not provable, becomes cogently pertinent science that is not refuted and yet feasible.
Limitations	Limits are frequently not stipulated, yet often reflects unrecognized components of research, particularly in the extra-dimensional context.
Results	<ul style="list-style-type: none"> • Feasibility based on jigsaw pieces but not falsified: <ul style="list-style-type: none"> ○ <i>Creativity and originality</i> ○ <i>Metaphysical jumps to scientific approach</i> ○ <i>Exclusion of data</i>

Consensus is sometimes based on outmoded concepts not on truth.²¹ This consensus approach to scientific investigation is always based on our limited knowledge of the nature of reality. Many new hypotheses, based on a deeper and/or broader understanding of the nature of reality, are possible. The literature of what is known is constantly changing as more is learned or applied about the true nature of reality; for example, new light was shed on the nature of reality by relativity^{22; 23}, quantum mechanics²⁴ and Gödel’s incompleteness

theorems,^{19; 20} yet the scientific approach has not been modified to accommodate them. Additionally, both in the feasibility and in the falsifiability approaches, new axiomatic mathematics and logic are introduced as critical “players”.

Issue 2: Resolving the scientific approach by amplifying the Philosophy of Science

When we combine falsifiability and feasibility, we delineate a new Philosophy of Science approach called ‘Lower-Dimensional Feasibility, Absent Falsification’ (LFAF) as in Table 2A, which describes the key concepts

<i>Table 2A: Philosophy of science key concepts</i>	
Philosophy of science (PoS):	The branch of philosophy that examines the foundations, methods, and implications of science. PoS includes what science is, its pertinence, reliability, purpose, ontology, and areas related to science, such as metaphysics.
Falsifiability (in the scientific context): <i>Strength:</i> <i>Limitations</i>	Carl Popper’s concept: ² The empirical or mathematical demonstration of the falseness of a hypothesis. The level of proof is a negation and falsifiability is often in practice, limited to aspects of our <i>current experiential</i> reality of 3 spatial dimensions (length breadth height) in a moment in time (the present) and therefore called 3S-1t. Falsifiable in LFAF refers specifically to scientific falsifiability not any other common synonymous uses such as “incorrect”, “erroneous”, “mistaken”, “inaccurate”, or “imprecise”. <i>Falsifiability’s strength:</i> it is a powerful way to negate an incorrect hypothesis. <i>Falsifiability’s limitations:</i> it is insufficient for cosmological concepts like evolution, and can frequently not be applied beyond 3S-1t, particularly if events or objects are not falsified.
Feasibility (in the scientific context): <i>Not the CF context</i> <i>The strength of SF:</i> <i>Limitations of feasibility</i>	Vernon Neppe’s concept: The empirical or mathematical demonstration of the manifest portion of something that we can experience, perceive, or conceive of, that is not falsified. Feasibility, like feasibility, refers to something that is testable and involves demonstrable proof by empiricism, deduction or induction: It involves descriptions of attempts at scientific proof —“scientific feasibility” (SF). However, there is an alternative non-scientific English idiomatic use —“common feasibility” (CF): This common linguistic use of feasibility “it is possible (or probable) to do or effect something easily or conveniently” is different from SF. “Feasibility” is as SF only in this paper as part of LFAF. (SF) Feasibility is more versatile than falsifiability in that it can add meaningful reasoning to different scientific contexts such as extra dimensions, evolution, cosmology, meaningful medical practice, psi, and even extend mathematics and logic. SF manifests like filling in a jigsaw puzzle piece into the experiential stage of 3S-1t. But this more multifaceted feasibility <i>lacks the power</i> of falsifiability analyses.

But some disciplines must be part of science yet require LFAF to be so. Sometimes, we don't even recognize that we're using LFAF. In table 2B, we list the key LFAF elements.

Table 2B: Lower-Dimensional Feasibility, Absent Falsification

<p>“Lower-Dimensional Feasibility, Absent Falsification” (LFAF):</p>	<p>Neppe and Close in 2012¹ developed this new theoretical Philosophy of Science approach to scientific proof. The basis of LFAF includes logically feasible concepts in hypotheses that may not be falsified or even falsifiable in our experiential reality of our three dimensions of space embedded in the present moment in time (3S-1t). LFAF is applicable at all dimensional levels and allows a greater versatility of scientific approach without excluding the greater power.⁸ Applying our <i>dimensional domain</i> of 3S-1t that we experience while alive, we could have named this method of analysis “3S-1t FAF” (or “3S-1t feasibility, absent falsification”). This would have been perfectly logical. But it eliminates the option of other analyses, relative to different dimensional frameworks.^{10, 11}</p>
---	--

These disciplines and specific areas need to be respected as sciences. Yet, they often cannot apply the scientific method because falsifiability alone is not available or relevant. Applying “feasibility” makes them meaningful: Paradoxically, these disciplines are currently regarded as sciences, yet it is the scientific feasibility (SF) that’s more pertinent as the LFAF approach makes them sciences that can be carefully examined for their data (Table 2C).

Table 2C: The disciplines and specific areas that demand to be sciences

<ul style="list-style-type: none"> • Medicine emphasizes clinical pertinence. Clinical relevance in medicine is more important than statistical correlations. The medical approach is often bidirectional with correlations in medicine (dual directional “causality” or linkage)^{25 26; 27; 28}
<ul style="list-style-type: none"> • Evolution reflects the historic past, and feasibility assumptions need to be made about this discipline because it is often inherently not falsifiable.
<ul style="list-style-type: none"> • Cosmology: Cosmological findings often involve applying pieces of the jigsaw puzzle and testing for feasibility because the distances and times involved are astronomical.
<ul style="list-style-type: none"> • Dimensional biopsychophysics (DBP)[§] involves studies of dimensions. This includes dimensions beyond the usual 3S-1t that we can directly experience. We can sometimes only be aware of the extra dimensions only through little clues manifesting in 3S-1t: We call these jigsaw puzzle pieces. These should be scientifically feasible. DBP interfaces and impacts several areas such as biology, physics, and consciousness research.

Concepts like feasibility and falsifiability reflect not only scientific methodological approaches. They are actually fundamental to the *Philosophy of Science approach* to conceptualizing science. The concept of LFAF broadens science in the disciplines of

[§] Dimensional biopsychophysics: This is a new discipline established by Neppe and Close¹ to fill the void of how to describe multidimensional reality in the physics, biological, consciousness and psychological sciences.

evolution, cosmology, dimensional biopsychophysics, and particularly in common practice, in medicine.

Falsifiability is quite insufficient to deal with all our current sciences. Applying LFAF allows for more versatility plus more power to expand hypotheses and results. LFAF is particularly pertinent to accentuate the disciplines and concepts listed in Table 2B, significantly broadening science, including evolution, cosmology, and multidimensionality and making medical interpretations more meaningful and applicable and allowing the introduction of new disciplines, such as dimensional biopsychophysics.

Table 2D: Concepts that demand to be scientifically evaluated

- **Life:** “Life” is far more than the physical testable RNA and DNA expression. Biology involves the feasible as experienced in 3S-1t only, just as physics does, yet the beginning of life might not be falsifiable, and, we argue, appears to be far more than just 3S-1t.⁸
- **Ordropy:** Order can be reflected in finite multidimensional order. Moreover, we have argued that such “ordropy”^h might derive from the infinite continuity. At that level, it is inherently not falsifiable, but we might experience the feasible jigsaw pieces in 3S-1t.
- **Infinity:** Infinity integrates with the finite and transfinite, and we argue, embeds this metafinite.^{i 8} The continuous infinite is extremely difficult to conceptualize and because there are no measures, much of it must be inherently non-falsifiable. Moreover, the quantized finite extending into the transfinite may be difficult to measure, except at times, ordinally. This, again, might lead to data that cannot be calculated exactly, and therefore cannot easily be falsified, yet can be feasibly examined.
- **Psi :** *Psi phenomena*^j cannot be explained other than recognition that they appear beyond space or beyond time or require greater consciousness. This means that they are “relatively non-local”.^{8, 10; 11; 29} We postulate they involve at times extra dimensions beyond 3S-1t. They therefore fit into the discipline of Dimensional Biopsychophysics.

Practical non-falsifiable science

There are, therefore, special circumstances in which the classical approach of Karl Popper in the Philosophy of Science³⁰ that requires only “falsifiability”, do not apply.

Issue #3: Feasibility

Feasibility can, but falsifiability cannot, be applied to certain recognized scientific endeavors. These include not only evolution and cosmology. For example, certain models

^h “Ordropy: is the Neppe-Close term for multidimensional order.⁸ Ordropy is more than just a negation of entropy (implying a tendency to disorder). Its presence may relate to the ordered biochemistry that we, living beings, experience every moment, and the maintained order of our living. But it also has an infinite component, with a hypothesis of being the source of all order.

ⁱ “Metafinite” refers to the composite term for the “discrete finite” (such as the 9 dimensions), plus the higher transfinite.

^j Psi” is a composite term used for so-called “extrasensory perception” (ESP) and “psychokinesis” (PK). To the layperson, it is the generic term for psychic, paranormal, anomalous and sixth sense. Psi phenomena constitute part of the scientific discipline called “parapsychology”.

took some years to demonstrate: What were their statuses before they could be tested and potentially falsified? A classic example is Einsteinian General Relativity^{22; 23}. In today's world of theorizing, the Neppe-Close TDVP model¹⁸ has very strong areas of strength, but there are creative ideas and particularly concepts about infinity that have speculative components. Does that mean there is room for expansion? Indeed, yes: TDVP generates some 600 hypotheses, and about 20 have been definitively demonstrated.⁶ These examples cannot be solved with Popperian falsifiability alone², but they can by applying LFAF.

We amplify other apparently legitimate scientific endeavors:

When we study “dimensions” that might exist beyond “3S-1t”, we’re examining an ostensibly critical area. Dimensions relate not only so for psi phenomena, and even more so for alleged survival after bodily death⁸. They are also pertinent for models in mathematical physics, such as models of indeterminacy, entanglement, and solutions for questions that are unsolved by applying 3S-1t.¹⁶ This includes conundrums⁶ such as the mixing angle⁵, intrinsic angular momentum and intrinsic electron spin³¹, the disappearing electron cloud^{32; 33}, pure mathematical 9D spin calculations, weak universality³⁴, and the possibility of either the non-spherical electron or questions about light speed³³. Effectively, these are examples of the 9-dimensional spin models that have been demonstrated through the Neppe-Close TDVP model.^{5; 6; 7; 8; 9}

Because these models cannot be represented in 3S-1t alone, they need to be portrayed multidimensionally (in this instance in 9-D). This means that only some incomplete pieces of the metaphorical jigsaw puzzle can be reflected in 3S-1t alone, allowing for representations of feasibility even when not falsifiable.^{8, 17}

Additionally, there are areas that do not necessarily reflect specific numbers of finite dimensions, like the 9-dimensional spin demonstrated by TDVP⁸, but can be applied to any number of dimensions that fulfill certain stipulated conditions.

Feasibility examinations, also, may be non-specific. In this context, they may allow for broader mathematical studies. These include the multidimensional geometry that we have called “dimensionometry”^k, the mathematical ways to move across dimensions called “dimensional extrapolation”^{1 8}, the Calculus of distinctions (CoD), which is the new calculus involving quantal not infinitesimal analysis^m, and the extension of CoD called “the calculus of dimensional distinctions”^{n 35}. Finally, there is the important complex process of

^k dimensionometry^{3; 4} The logic and mathematics of geometry extended to include further dimensions. These domains include at least nine dimensions.

^l dimensional extrapolation^{3; 4}. A mathematical dimensionometric process for defining the dynamic relationship of dimensional domains and number theory through rotation and projection.

^m Calculus of distinctions: (CoD)^{3; 4} Well-defined logical and mathematical operations involving the drawing of distinctions, constituting the most basic concept underlying all logic and mathematics. Particularly relevant to TDVP are distinctions of content, extent and impact. The CoD was developed by Ed Close, who was later assisted by Vernon Neppe.

ⁿ the calculus of dimensional distinctions^{3; 4} (CODD). The CoD with extended notation and detailed operations applicable to finite n-dimensional distinctions.

movements across dimensions called “indivension”.^{o 8}

If we decide to ignore such ostensible areas of contradictions in the applications of scientific method, we may be missing much of what constitutes reality. At least, these endeavors should be given the opportunity to be examined scientifically.

Feasibility is sometimes much more pertinent in Medicine than falsifiability.

Furthermore, there are areas where falsifiability is not a key element, but whether that potentially falsifiable area is “feasible”.

A practical example here involves medical pharmacological studies. If a drug works better than placebo such that it achieves falsifiable statistics at the one in a thousand level, the result might well potentially just be reflecting a 51% improvement on the drug compared with 47% on placebo. However, the statistical power might relate to say, 5000 patients being in the study sample. Moreover, such a result could even be replicated. Indeed, the USA Food and Drug Administration mandates two double-blind studies for the drug to be approved as efficacious and hence marketed. Yet, would a doctor use such a drug?

In Medicine, we have a higher level of expectation than just results that can show that a medication may work better than placebo in 4% or 10% of cases. What matters in clinical practice are the results. The patient must get better or at least consistently improve with the proposed intervention. That is our measure of success. It is not measured by the result of a double-blind study with slight differences only sufficient to make the intervention better than placebo.

Effectively, we need to prescribe an appropriate antibiotic, based on demonstrable marked specific bacterial sensitivity that allows the confident prediction of the patients improving in perhaps 98% of cases. Consequently, *falsifiability* is limited in relevance in Clinical Medical Practice. It might work statistically, but the clinical significance relates to whether it is *feasible to use the drug*, not the results of any double blind studies that generate statistical, but not clinical significance. What is relevant is, “*is that prescription feasible?*”.

Therefore, we must add to the most usual scientific approach of falsifiability by recognizing that there may be legitimate reasons to apply another level of scientific proof, namely “is it feasible?” This paper is about feasibility and extending of the Popperian idea of falsifiability² to what we have called “*Lower Dimensional Feasibility, Absent Falsification*” (*LFAF*).

Issue #4: The critical role of mathematics in Science.

We point out that there is more to the scientific approach by examining just falsifiability. We must recognize that science extends beyond that. Is the information obtained from the research, theoretical extension, or other scientific approach feasible? Sometimes, it might be

^o indivension^{3;4}: A new TDVP term (derivation: Individual-units; dimensions): the process of moving across, between and within dimensions, and interfacing across different levels of social systems.

just the overt component of the total potential data set that is available. It's like a piece in an incomplete jigsaw puzzle, filling in one more 3S-1t section in a vast infinite expanse.

We argue that mathematics is a very definitive way to establish scientific proof and can be applied for key feasible and falsifiable events in science (Table 4A).

<u>Axiom:</u>	A feasible statement or proposition that is regarded as being established, accepted, or self-evidently true.
<u>Conjecture:</u>	An unproven supposition, opinion or conclusion, which is feasible and often well supported, based on incomplete information
<u>Contradiction</u>	(Mathematics) A combination of statements that are incompatible.
<u>Corollary:</u>	A feasible or falsifiable proposition that follows from (and is often appended to) one already proved: a direct or natural consequence or result.
<u>Derivation:</u>	A falsifiable sequence of statements showing that something (like a formula or theorem) is a consequence of previously accepted source statements.
<u>Equation:</u>	A falsifiable statement that the values of two mathematical expressions are "equal to" (=) or "equivalent to" (\equiv).
<u>Exponent:</u>	A quantity representing the power to which a given number or expression is to be raised, usually expressed as a superscript (e.g., the n in x^n)
<u>Inequality:</u>	The falsifiable symbolic expression of the relation between two expressions that are not equal, employing signs such as \neq "not equal to" ; at times, $>$ "greater than, " or $<$ "less than".
<u>Integer:</u>	A whole number (positive or negative); a number that is not a fraction.
<u>Lemma:</u>	A falsifiable subsidiary or intermediate theorem in an argument or proof.
<u>Proof:</u>	Evidence or argument establishing or helping to establish a fact or the truth of a statement (at its most proven level, it is falsifiable)
<u>Theorem:</u>	A general, usually falsifiable, proposition that is not self-evident but proved by a chain of reasoning; a truth established by means of accepted truths; in mathematics, rule in algebra, geometry or other branches of mathematics expressed by symbols or formulae.

Even though statistics may justify research, the proofs of mathematical logic are the most powerful ways to demonstrate scientific results. We personally regard mathematics as a fundamental component of reality, not just a way to carry out calculations. (Table 4B).

<ul style="list-style-type: none"> • <i>Either</i> mathematics is relevant to science. If so, we can incorporate math within nature and it is part of the scientific empirical and inductive methods (Plato) • <i>Or</i> mathematics is irrelevant to science, and purely applied just as a method of calculation, however it still is a powerful method of proof (Aristotle).
--

Among current mainstream scientists, there is dispute as to which of the dichotomous interpretations of the basis for the application of mathematical logic are correct. This is not new, as even the great ancient Greek philosophers, Aristotle and Plato, disagreed on this issue.³⁶ Plato saw mathematics as the secret to unlock the mysteries of the universe. Aristotle understood the great utility of mathematical methods. Essentially, does mathematics just involve a mechanical calculation? Or is it more than that? Is mathematics a fundamental part of the natural logic underlying the empirical results obtained by the experimental investigation of reality? This latter choice allows us to appreciate the beauty of mathematics, but even more so, particularly, the necessary role played by logic and math in reality. In a way, it allows for further meaning because strange derivations of formulae and of constants become meaningful. Such exact numbers allow for a feasibility which may reflect an important component of reality. However, either way mathematical logic is critically important and mathematics has a value in the approach to scientific proof, relevant in applying both the falsifiable and the feasible.

Table 4C: The three endpoints of mathematics applying empirical and inductive methods

- Mathematics allows for demonstrable proof: The derivation is then replicable.
- Mathematics cannot prove something: The question or theory remains open.
- Mathematics definitively proves something is incorrect: This is often reflected by an “inequality” and the consequence is recognized as a “contradiction”.

Very relevant might be situations where mathematics shows that two sides of the equation are unequal. This creates an inequality. Sometimes, further limits may need to be stipulated, as in Fermat’s Last Theorem (FLT) which mandates an inequality under the limits of the theorem (exponent $n \geq 3$) because the result required must be integral, not a fraction, so that there is no solution and the two sides of the equation must necessarily be unequal.³⁷ In this instance, for centuries this was a *feasible conjecture*. Then the inherent *contradiction* in the equation was demonstrated when it was *falsified* and so FLT truly became a proven *theorem*.

As another example, the stipulated *limits* of 3S-1t turned out to be insufficient for a *falsifiable* solution to mathematically deriving the Cabibbo mixing angle³⁸, but such a derivation was nevertheless *feasible* as a proposed idea that could be based on a 9 dimensional spin model as hypothesized by TDVP.¹ When Close and Neppe went beyond 3S-1t and tested that hypothesis, it became falsifiable and was proven^{5;7}. Moreover, it could easily be mathematically replicated, and based on the same original hypothesis based on the hypothesis that the quantized finite elements of TDVP that 9 vortical dimensions must exist¹, the authors have used similar 9-dimensional spin principles to demonstrate several other findings.^{5; 6; 7; 8; 9; 39; 40}

Importantly, this kind of example makes what could otherwise have been labeled as “metaphysical”, and abandoned as one of those insoluble quantum mysteries. It is insufficient for the Physics “Nobelists of the people”, Richard Feynman to write that they cannot be

understood or explained.⁴¹ *They demand solutions for us to continue scientific progress.*

But looking at the feasibility of the data, potentially allows us to examine ideas that are more creative scientifically. And finally, this allows an additional logically consistent way in which information that is feasible as pieces of the 3S-1t jigsaw puzzle can be included as part of the puzzle that is reality.

Issue #5: Amplifications of specific scientific data approaches

Deductive reasoning is a very common scientific technique, based usually on *empirical observations*. However, *inductive reasoning* is very relevant particularly when not all data is available to directly observe. This may require *inferences* to be made. There are many pertinent technical and/or operational terms in scientific approaches relating to analyzing empirical data (Table 5A).

Table 5A Techniques of scientific data approaches

<i>Deduction</i>	By contrast, involves the inference of particular instances by reference to a general law or principle.
<i>Derivation</i>	Mathematically, the process of deducing a new formula or theorem from previously accepted statements or sources of origin.
<i>Empiricism</i>	Is based on, concerned with, or verifiable by observation or experience rather than theory or pure logic (Popper ²)
<i>Induction</i>	Involves the logic of inference of a general law from particular instances. The extension is the <i>observation-inductivist</i> method (opposed by Popper ^{2; 30; 42}) of indirect testing only, applying theory and understanding implications. The Neppe-Close jigsaw puzzle in LFAF may be an example here, applying the principles of feasibility without being falsified.
<i>Inference</i>	Involves the process of deriving logical conclusions from premises or findings that are known or assumed to be true.
<i>Jigsaw puzzle pieces</i>	The Neppe-Close TDVP concept applies mainly to our current experience and observations, where little pieces are added that may be pertinent for analyzing other dimensions. These pieces may be discrete bodies of conceptual, theoretical or empirical data.
<i>Mathematical induction</i>	Applies one or more means of proving or disproving a theorem by showing that if it is true of any particular case, it is true of the next case in a series, and then showing that it is, indeed, true or false, in another particular case. Proofs by infinite ascent or descent are examples.
<i>Observation</i>	In science, what is directly observed: Direct evidence or experience through the senses that gives rise to documentable empirical data.
<i>Replicability</i>	Scientific technique showing that positive findings can be repeated: A strong indicator of validity: If the same results are obtained every time an experiment is performed, it is said to be replicable.

Deductive reasoning is a very common scientific technique, based usually on *empirical observations*. However, *inductive reasoning* is very relevant particularly when not all data is available to directly observe. This may require *inferences* to be made. These inferences are legitimate and critically important in many sciences. Inferences might be applicable to basic physics observations —how many times do apples need to fall downward off a tree to infer gravity? Inference and with it inductive reasoning, are always legitimate scientific methods.

Inferences might be applicable to basic physics observations —how many times do apples need to fall downward off a tree to infer gravity? Inference and with it inductive reasoning, are always legitimate scientific methods.

We can combine our inferences with examples from two critical disciplines where inferential feasibility is critical, namely, the Medical Sciences, and in Dimensional Biopsychophysics.

Medicine: In Medicine, physicians and their patients pay great homage to falsifiability and recognize statistically the relevance of double blind studies to demonstrate basic efficacy. However, clinically in practice applies inferential thinking for life-and-death decisions: Patients do not want to know they have 5% chance above placebo chance to survive or get better; they want what is feasibly the best treatment.

Indeed, the basis of medical practice involves inference in both diagnosis and treatment. Inference is extraordinarily important in *medical causality*, a scientific discipline that functions predominantly on inferred data. Neppe^{25, 43}, and also Neppe and Close^{10, 11, 24, 44}, have indicated these feasibility assumptions may be very powerful as the causality is often “bidirectional”. For example, when the level of the laboratory test of “HbA1C” is high it demonstrates diabetes and we can predict the characteristic symptoms we will expect. But the diabetes condition also has a cluster of specific symptoms strongly suggesting the diagnosis and when that occurs, it is almost invariably associated with a raised HbA1C level. This makes us able to predict the linkage in either direction. Consequently, when either option happens the feasible medical diagnosis inferred would reflect diabetes. But for any specific individual patient, the diagnosis may not be falsifiable because that might require a statistical analysis of many patients with those specific symptoms (of course, such general symptom analyses exist overall for diabetes patients, but not necessarily with the exact symptoms and severity of the specific patient being analyzed.).

Dimensional Biopsychophysics: Next, we turn to Dimensional Biopsychophysics (DBP), applying particularly the concepts in Table 5B, to appreciate the particularly relevant role of inference in multidimensional frameworks. In DBP, the multidimensional spectrum involves applying what is feasible when it might not yet be, or even ever will be falsifiable. So frequently, we’re applying the inferential spectrum, but applying inductive reasoning. This allows us to further scientifically interpret key new and old data using LFAF.

We can add to these common concepts: We integrate new language, ideas and notions to the multidimensional, and link distinctions with various dimensional levels (Table 5B).

Table 5B: The milieu of dimensional science

9-D	Nine dimensional model: This was first postulated in TDVP ¹ and then later derived. ⁸ 9-D involves nine dimensional spin and incorporates the lower dimensions and all the science in them such as 3S-1t.
Restricted 3S-1t (-1+C): ^{3; 4}	The restricted reality that we, sentient beings, experience during physical life associated with limited perception and responses. Most of reality is hidden at the various relative non-locality levels. ^{10; 11}
Distinction: ^{3; 4}	Anything that can be distinguished, in any way whatsoever, from everything else: Any finite object, event, image or thought distinguishable from its surroundings.
Dimensions: ^{3; 4}	Non-congruent, non-parallel extensions measurable in terms of variables of extent (CoD) such as Space, Time and (dimensional) Consciousness. Operationally, in the Euclidean framework, for convenience, dimensions are defined as orthogonal to each other and characterized in degrees of freedom. A continuous distinction that can be measured in units of extent. These interact together forming different domains with specific properties.
Infinite: (TDVP): ^{3; 4}	Limitless, unbounded, continuous, without end subreality in Space, Time and Consciousness (C-) Substrates. <i>The infinite subreality contains the finite</i> discrete and transfinite subrealities. Infinity involves a continuous subreality, that obeys the laws of nature, but we conceptualize the gestalt—the whole—and the total content of infinity is almost completely unknown.
Metafinite: ^{3; 4}	(Neppe-Close TDVP). The discrete transfinite plus the lower finite dimensions. All the discrete, quantized, pixilated. Embedded in the infinite continuity (see “Transfinite”).
Metaparadigm: ^{3; 4}	Broadest paradigm impacting all sciences, mathematics and philosophy.
Transfinite: ^{3; 4}	The transfinite is sometimes called “countable infinity”: Realistically, the number is so large, it blurs and by definition cannot be counted. However (in TDVP), “transfinite” essentially still involves a discrete extent (so it is technically quantal though ordinal in measure). Transfinite is contrasted with the “infinite” that is never discrete or countable, though continuous, but the “finite” also includes the lower dimensions. In TDVP, we sometimes refer to the “transfinite” as the “tenth-plus dimension”. ^{22; 23}

The concepts behind multidimensional realities are necessary because we can observe only partly what is happening, namely the overt 3S-1t expression, with the rest of the 9 dimensions (for example) or of the transfinite, or even the infinite, being covert, because we cannot access the other dimensions. We have to infer, and apply what is feasible, because we usually have data that is not yet falsifiable empirically.

Many of these dimensional concepts can be applied mathematically, by derivation which generally involves a higher level of proof⁶ because data can be deduced incontrovertibly. This is why the examples of the Close and Neppe derivations of the Cabibbo angle⁵, intrinsic spin and the angular momentum³¹ and the electron cloud^{28; 29} are so powerful. They may turn contemporary scientific consensus on their sides, but they provide little alternative to accepting a new heresy, that our world may be an experiential reality in 3S-1t, but that 3S-1t is embedded in a further finite 9 dimensional existence. This is so as the mathematics even proves that these falsifiable calculations can be derived and potentially replicated by others applying the same approach. And the fact that there are several different examples applying 9-D spin makes the argument against this just involving “operators” and not reality based data, even more cogent^{6, 45}. And the fact that the initial LFAF hypothesis was based on the proposal that specifically 9-dimensional spin was feasible as suggested by the data that was available through the Neppe-Close TDVP model^{5; 6; 7; 8; 9}, makes it empirically confirmed.

Dimensions are extraordinarily important, and require their own extensions of mathematics. For example, each higher dimension contains the dimension below, and this continues until the zero dimension of a single point. But there may be, , in empirical finite reality, no single point—no singularity, so to say— because everything is quantized.

We can look at dimensions in terms of each making distinctions from each other. Once they go beyond 3S-1t into the extra usually covert dimensions, they require feasibility evaluations.

Issue 6: Amplifications of logical scientific data approaches

We can understand the complexity of the mathematics behind dimensions by recognizing the different *existential distinctions*^{35, 8}:

- *Extent*: dimensions are measurable—they have extent in space, time and “Consciousness extent” (STC_x), applying either interval or ordinal measures.^p
- *Content* is the second existential distinction, in this instance mass, energy and “content of Consciousness” (MEC_c)
- The third distinction is the *impact* of these factors on the content and extent. This can be through physical Mass-Energy results (e.g., the influence of earthquakes) or through the “impact of Consciousness” (C_i) on STC_x or MEC_c.

This all can be further developed by the mathematical technique called the “calculus of

^p We introduce here three different existential levels of Consciousness: C_x, C_c, and C_i, for extent, content and impact of Consciousness, respectively.^{35, 8} Often, scientists do not recognize that these three major distinctions are different and apply “like” with “not like”. This might produce an incorrect outcome as the three concepts are different.²⁵

distinctions” (CoD). Applying LFAF, at the 3S-1t levels, this is often *falsifiable*. But at the higher dimensional levels, the math may or may not be *falsifiable* because we need to be able to prove it, but it remains *feasible* in 3S-1t, even though it involves extra dimensions.

One important mathematical-logic approach is to apply the “*calculus of dimensional distinctions*”³⁵ (CoDD). This extends the CoD across to the many dimensions that we cannot directly experience.^{3,4} The CoDD can be applied to the example of our experience of existential distinctions (Table 6A).

Table 6A: Distinctions and dimensions (falsifiable or feasible or both)

- Distinctions are characterized by triads involving separations e.g., of self and not-self
- Existential distinctions reflect everything that exist, like the quantized, discrete finite and transfinite contained in the continuous infinite
- Experiential distinctions involve our experiential frameworks (e.g. in 3S-1t) with perceptions, conceptualizations and interpretations
- Higher finite dimensions mathematically involve the calculus of dimensional distinctions.

Four separate points are pertinent:

- *The 3S-1t jigsaw pieces*: At times, our 3S-1t experiences are influenced beyond those overt dimensions. Yet, we can only find small missing clues in 3S-1t: This is what we call the “*jigsaw puzzle*” pieces. This jigsaw is particularly consequential as it establishes that certain findings though not *falsifiable* in 3S-1t, may be *feasible* enough to continue making hypotheses and testing them, if possible, or as necessary. These jigsaws express little components of the multidimensional in 3S-1t, and, conversely, might reflect impacts that are extremely pivotal in higher dimensions.
- *Role of math*: Mathematics frequently allows scientists to use higher levels of certainty, because the resultant proofs are, at times, incontrovertible. Mathematics even plays a critically important role in scientific inductive techniques.
- *Exact repetitions*: Finally, in the rare instance of the situation repeating itself exactly, we would want to *replicate* any experiment or even spontaneous data. But most of the time, we cannot. We simply never have the exact circumstances.
- This means that *replication is necessarily inexact*. At least something changes in our dynamic world every moment—there is never a situation where everything is the same. So effectively, real scientific experiments are only very rarely truly replicated. However, that sometimes does not matter (as in Physics) but does in Psychology or in Psi research.

Replication in Physics is easier because the reality of subtle changes that may confound such as temperature, weather, individuals present, or precise methodology might seldom make a difference to such research: A piece of metal may require specific amounts of force to bend in a particular way, and someone who is anxious and depressed could implement that change as easily as another with normal mental status. But try that with replicating a *Psychology Experiment* on (say) measuring attention span. There the confounding anxiety and depression would be critical. Similarly, those same confounders in *Consciousness Research* might be critical and result in a failed replication, or even be regarded as a different experiment.

Issue 7: Is replicability sufficient?

“Replicability” is a critically important concept in “science”. This involves scientific techniques showing that positive findings can be repeated. Indeed, there are those who would argue that science involves replicability. Replication is, in effect, the positive expression of the negative that is falsifiability. By replicating, we demonstrate that we can predict that our experiments or observations can be repeated, at will. This is very powerful. In contrast, by falsifying we are stating that a specific circumstance is negated. Both are closely linked with LFAF.

The absence of falsification allows us to continue our probe. Whereas the data may not be exactly expressed such that we can replicate, by applying another jigsaw piece we get closer at least to beginning to repeat the experiment and finding the data still works: It’s repeatable.

There are, nevertheless, certain circumstances that apply the best scientific methods but cannot be replicated. Psi phenomena are the classical examples. Does this make “psi” necessarily unscientific, the limitations of our ability to obtain the same circumstances every time, relative to replication of any experiment: The, so to say, Eddington thought description that started this paper, where the smaller fish fall through the nets? ¹⁴

Most times, as in so-called “hard science” such as macroscopic aspects of physics, subtle differences are unimportant. But even then, circumstances such as the exact weather, corresponding time of day, even the sidereal time ⁴⁶, the emotional state and the broader attitudinal traits of the experimenters ^{47; 48}, the subjects, and anyone else involved in the experiment, cannot ever be replicated exactly. The experiment is always subtly different. In psi, this is critical. Does this mean that this is not ever scientific? It certainly does not. It means we have to be very careful with our fishnets and recognize the inherent limitations.

<i>Table 7A: Nine areas of psi demonstrating 6 sigma data ¹²(less than one in a billion against the event statistically occurring by chance). ⁸</i>
• <i>Ganzfeld</i>
• <i>Global Consciousness Project (GCP)</i>
• <i>Remote Viewing (RV)</i>
• <i>Random Number Generators (RNGs)</i>
• <i>Presentiment</i>
• <i>Bem protocol</i>
• <i>Less Usual Six Sigma Protocols</i> <ul style="list-style-type: none"> ○ <i>Staring protocols</i> ○ <i>Survival after bodily death</i> ○ <i>Precognition and Six Sigma Data</i>

Experimental psi phenomena in the living appear very fragile, requiring careful controlling of many pertinent variables. This may be why we need to pool several studies. That has the advantage of overall increasing the power of the data, but also washing out several otherwise confounding circumstances that might otherwise be variables such as experimenter effects, sidereal time and exact locations. Let's look at Table 7A as an example illustrating the statistical data on psi.⁸ Eight of the six sigma results are based on meta-analyses. The “survival” analysis is based on individual data.

Ironically, even such experiments when examined by meta-analyses, and therefore eliminating confounding factors, are replicable in many instances. If needed such studies generate remarkable statistics exemplified by the nine different areas of psi that generate frequentist statistics of six sigma levels—about less than a one in a billion against chance statistic!⁶ However, the power of each study was usually small, and replicability generally would require only very large sample sizes. This has led to the difficulties encountered in parapsychological research of proving individual hypotheses.

Whereas, sometimes some data is demonstrable without meta-analysis, the statistical *replication* of adding together many studies is an excellent way to remove confounding factors because effectively the different factors dilute themselves. Interestingly, such an approach moves data analyses from what would not have been regarded as falsifiable or replicable, but feasible to analyze, to the level of falsifiability and replicability (Table 7A). However, what the results demonstrate is simply what the data shows. It is one step off from psi, in that it could be argued that the basis of the statistics could be biased from questionable response protocol measures. Instead, for many individuals, examples that provide intensely personal spontaneous descriptions are often more persuasive than even any profoundly significant statistics. Yet these events are not falsifiable, but the data is certainly feasible, and may involve many cogent pieces of jigsaw puzzle type proof. These experiences are what are vividly recalled, not e.g., that 53% of hits occurred when there should have been 50%!

Of course, the Table 7A data are based on so-called “frequentist statistical analyses”. And that says little about the research methods, simply the results. We know based on the history of psi research how careful researchers have been. Their whole methodology has been built on eliminating sources of physical or recording error, for example, more than in any other science in history—indeed, parapsychology has become the model for the sciences.^{49; 50}

Nevertheless, we could apply another kind of statistic, Bayesian priors.^{12 8} If we begin with the hypothesis that something is impossible, that the chances of it being true are zero, it does not matter that one is talking about one in a billion against chance statistics!^{12 8}

This argument has some legitimacy: Marcello Truzzi has argued that “*An extraordinary claim requires extraordinary proof.*”⁵¹ Simply stated, claims of psi profoundly rock our current perspective. But as a supplement to statistics, we may need to add spontaneous data,

and personal experiences to such data: This way the individual scientist may perceive it as “feasible”, whereas with the statistics alone, he or she may require other supporting evidence.

Moreover, there might be areas with evidence and even proof in science that could not initially be replicated. Sometimes this was because solutions had not been discovered, as with the Close derivation of the Cabibbo mixing angle.^{5; 9; 52} This is an example of where for fifty years the solution was regarded as insoluble, but it had only previously been examined within the 3S-1t perspective. The solution required applying the data beyond 3S-1t, in this instance, in 9 finite dimensions: At that point, the result could be mathematically derived.

Even more so, some analyses might involve proofs requiring the infinite, and we simply have insufficient data about the infinite. Yet without incorporating the infinite into the model, Gödel’s incompleteness theorem might come into effect so that the data would be insufficient mathematically^{19; 20}. However, if this cannot be falsified, the jigsaw pieces in 3S-1t, at least provide semblances of feasibility.

Issue 8: Re-examining the fundamental concepts of science

Prof. Henry Bauer has written a remarkable paper²¹ which encapsulates too some of his larger writings like books.⁵³ We’ve found correspondences of many aspects of the difficulties he points out, with the points we’re also making. Both Bauer⁵³, and Neppe and Close⁵² recognize the limitations of science as we know it today⁴⁴. Let’s crystallize science as we know it.

Bauer indicates that there is no (totally) satisfactory definition of “science”: Does it apply “the scientific method”?²¹ Not always. If science is quantitative like the “hard science” of physics, then economics is also a hard science because it, too, is highly quantitative and technical. Does science require applying mathematics and is that itself a science? We certainly believe that math is very useful, but it’s not a necessity. Mathematics, is so to say, a metalevel above science because mathematical proof is so definitive. Moreover, we argue that mathematics pervades all disciplines, not only as solutions but also as an integral part of reality. Whether then it is part of science is a question of definition: Whether science can be expanded to that metalevel.

Does science necessarily require examination of Karl Popper’s major thesis, that science involves examining only potentially falsifiable events?^{2; 30; 54} We’ve seen that feasibility and LFAF extends this, and therefore, falsifiability is sufficient but not necessary.

Is science supposed to be an “objective, value-free, and unbiased” method²¹? In practice, this cannot be so: The scientist necessarily bases ideas on his—and often the consensus’s—subjective and historical impressions. But this may be false to begin with. To Bauer, “*mistaken views about Nature have often enough disproved themselves (eventually)*”. Science “self-corrects” a great deal, but then, as Bauer points out, it must have been untrue before it self-corrected.²¹

Science is now subject to anonymous peer-review, yet this “*does not shield people from being jealous, opportunistic, self-serving, or harboring idiosyncratic beliefs, nor does it ensure competence or ethical behavior.*”²¹ This, indeed, is a problem for all these reasons: Rejection of the new, threats to current thought, even misappropriation of ideas.

Certainly, we know historically that science is resistant to new scientific discoveries!⁵⁵ Bernard Barber cites many, many examples through the ages of discoveries incorrectly criticized and dismissed by contemporary peers. These range from Galileo (and the Church) on cosmology, to Lister and, separately, Semmelweis on anti-sepsis, to Mendel on heredity, Helmholtz and Faraday commiserating on their individual rejections, Planck’s experiences on quantum theory, and Einstein’s isolation particularly from 1915 to 1919 on relativity. Even in modern days to the cause of peptic ulceration being bacterial (*Helicobacter pylori*). That initial ridicule ultimately led in 2005 to Marshall and Warren receiving the Nobel Prize.⁵⁶ Indeed, the history of creative thought can be conceptualized as the overwhelming denial of what then might have been unfalsifiable data. Without the next stage, LFAF, where feasibility is key, the little creative jigsaws would have been simply regarded as “metaphysical” not “science”. Now where LFAF with its jigsaw pieces begins, and true creative speculation based on mathematical logic ends, may be differentiated possibly by the known jigsaw type empirical data: But the exact lines to be drawn can be a source of debate.

As Arthur Koester famously pointed out⁵⁷: “*Innovation is a two-fold threat to academic mediocrities: it endangers their oracular authority; and it evokes the deeper fear that their whole laboriously constructed intellectual edifice may collapse.*”

And E Alan Price, and later Neppe, have amplified this: “*Moreover, in terms of the empirical ‘physicalistic presupposition’ involving the notion that all knowledge has its basis in what is physically perceived, and only physically, it is of course deceit and illusion to speak of knowledge based on non-physical perception and therefore, it follows that parapsychology is dealing with deceit and illusion.*”^{58,59} We are missing out on discovery.

To the pre-eminent Physics Nobelist, Max Planck⁶⁰ “*science advances one funeral at a time*”. He recognized that “*a new scientific truth does not triumph by convincing its opponents and making them see the light, but rather because its opponents eventually die, and a new generation grows up that is familiar with it.*” This is tragic to modern researchers. Moreover, to Planck: “*Truth never triumphs — its opponents just die out.*”⁶⁰

Certainly, as we envisage it, old ideas must be overridden and buried. This is not new: It was already a significant problem as long ago as 1943, as pointed out by Erwin Schrödinger⁶¹ in a lecture given in Dublin Ireland: “*We feel clearly that we are only now beginning to acquire reliable material for welding together the sum total of all that is known into a whole; but, on the other hand, it has become next to impossible for a single mind fully to command more than a small specialized portion of it.*”

Science today is an “umbrella” concept. And in today’s modern science,²¹ scientists appear to know more and more about less and less. How do they prioritize and see the bigger picture? Even “*overwhelming consensus in the scientific community*”²¹ does not imply that something is correct. Michael Crichton summarizes it:⁶²

“I want to point to what I consider an emerging crisis in the whole enterprise of science, namely the increasingly uneasy relationship between hard science and public policy.”

In legal court interpretations, we use levels of probability: On a more probable than not basis ($\geq 50\%$); clear and convincing evidence (say $\geq 80\%$); and beyond reasonable doubt (say $\geq 95\%$ postulated certainty)⁶³. Certainly, we would expect “feasible” in science to be at least at that $\geq 50\%$, but we would prefer it to be $\geq 95\%$ or even $\geq 99\%$ as we build that jigsaw puzzle. Scientists, individually, can, similarly, apply their own different levels of assessing findings.

In Table 8A, we refer to what we call the “*the 11NC revolutions*” (or “*11NCR*”): Of the 11 legitimate phases, individual scientists might be somewhat arbitrary as to which level of classification and even attaining a consensus of scientists might not imply they are correct. The spectrum ranges from complete individual rejection to scientific acceptance (Table 8A)

Table 8A: The eleven phases of denial and acceptance of Neppe and Close (“the 11NC revolutions” or “11NCR”)

1. Initially there is “*it’s too wrong to be wrong*”, often accompanied with a condescending smile or chuckle; the alternative phrase is the derisive “*it’s too false to be false*”;
2. then there is abject rejection, often accompanied by ridicule and name-calling: “*the insults are deserved. I know, I’m an expert*”;
3. then “*that’s a good try, but it’s simply not true*”;
4. then the consensus rejects it: “*it’s definitely incorrect*”;
5. then it is unlikely, but it may mentioned as a hypothetical for completeness: “*it’s an unlikely outlier that we mention just to cover all our bases*”;
6. there is the stage of “*I’m opting out: This is outside my discipline, so I don’t understand it or haven’t studied it. Let me suspend judgment*”;
7. then “*maybe there is something there, but I need more*”;
8. then “*there is some evidence... interesting*”;
9. then “*it appears to be proven: the evidence is cogent; but most scientist don’t accept that*”;
10. then it is hailed as “*it’s a new breakthrough*” (even though it may have been proven much earlier);
11. then “*it’s obvious: we all know that*”.

LFAF is an impetus for change but in the context of identifying different levels of acceptance in this new science. It ranges from utter rejection to complete acceptance (11NCR in Table 8A).

Where do we stand? In our opinion, *when so-called scientists write that “it’s too false to be false”, they’re saying a great deal, not usually about the science behind the work, but about themselves, because with the speakers’ ignorance or their resolute rigidity, flows forth their character.* We need to be very careful in going with the mainstream because creative endeavors and new discoveries are seldom driven by consensus. *“Essentially, substantive propositions should be answered substantively in every particular ... The greatest scientists in history are great precisely because they broke with the consensus.”*^{53 21}

So how, then, can we apply consensus and peer review, and maintain a paradigm or specific knowledge as science? Again, we need to apply LFAF, otherwise this might not even be a science at all and still simply metaphysical speculation or a philosophical standpoint. We, surely, must be careful that when using current consensus ideas, and rejecting feasibility, we regard the greatest contributions to science as “metaphysical” —implying they are non-scientific, sometimes creative philosophy. We might then recognize, too, the irony.

Wolfgang Pauli used different phraseology but with the same implications:⁶⁴ *“it is not even wrong”*. “Not even wrong” might conveniently be applied as an insult to areas such as psi, but linguistically it’s a contradiction because of the double negation. It might turn out to be correct, and this might be the ultimate back-handed compliment.

It would be interesting to establish if any of the “too false to be false” scientists, have ever in history made any creative contribution to knowledge. We would suggest that such dogmatic rigidity of thinking would prevent this happening.

Ironically, as Thomas Kuhn’s points out in his famous *The Structure of Scientific Revolutions*¹³, every contemporary mainstream belief or paradigm opposes significant change, and even more vehemently, resists any contradiction of the prevailing view. It can take a very long time before valid minority views become incorporated into a new mainstream. And as this is what produces change, the stability in our world-views is dichotomous: It’s good because new ideas might be wrong; and it’s bad, because it prevents legitimate progress.

And, ironically, familiarity may breed contempt: How can you, the reader, who may be close to us, be making a major contribution? Surely, it would be Professors Smith and Jones, whom we don’t know, because the grass would be greener on the other side?

Let’s apply 11NCR to the example that we’ve used: Let’s examine the data on 9 dimensional spin based on these revolutions of change. At what level would different scientists be? Would the data produce the pseudoskeptic denier of *“too false to be false”* at this Level 1. Or is it Level 5, *“this must be an unlikely outlier, because we’re concerned about all other 3S-It science”*? It’s hard here because we know that it does not contradict any of 3S-1t, it just extends it. *“So I suppose that still requires some denial of the data but at least I’ve compromised.”* Or is it Level 6, the honest *“I don’t understand it: This is outside my discipline”*? Could it be as high as Level 9: *“Respectfully, this proven: But most won’t*

accept it” ? Or is it deemed a Level 10 (“a new breakthrough”)? And what would it take to be Level 11? Would it require the Planckian funerals⁶⁰ or has massive, rapid electronic communications changed that ethos?

Thomas Kuhn's theory of scientific revolution encompasses a repetitive and ongoing cyclical transition that involves three stages¹³ namely:

- normal science;
- crises when paradigm shifts are contemplated or recognized with new assumptions; and
- scientific revolutions when the paradigm alters after a qualitative transformation in theory.

Through our proposed 11 Neppe-Close Revolutions model (11NCR), we have necessarily extended Kuhn’s various stages of understandings of the revolutions¹³ of change—the reshaping of science—by adding several more paths along the way. This results in eleven key periods of adjustment.

Kuhn describes the process of recognition, of discovery, of the crises and of the frequent failures, of alternative models, of resistance to the anomaly, of the transition to change, and ultimately of acceptance of paradigm change, at which stage the cycle repeats itself, but with added specialization of components of the paradigm.¹³

Of course, adding “feasibility” to the mix might paradoxically lead to being stuck on Level 1 of 11NCR for longer. Before it could just be rejected, but not as science, so maybe it would be classified as a Level 3 (“good try, but this is not science”). But now, for some, it might not be classifiable initially even as feasible, because of its ostensible Bayesian impossibility —“*the chances of it being true are zero no matter how strong the science behind it.*”^{12 8}. That may be why the Planckian Funerals⁶⁰ arguing against the limitations of advancements occurring are important. Scientists have great difficulty with “unthinking”!

These 11 stages are not easy to negotiate because they are so threatening, and we can see this in areas where, for many, the evidence is cogent, such as in psi research, and yet for others the data is completely rejected, often out of ignorance.

Scientists might not easily admit variants of the following sentences: “*I’m too threatened by this.*”; “*I want to stay with what I know.*”; “*In any event, I must not reject the conventions that I’ve studied. I’m an academic and my job is at stake.*” Instead, ironically, often those who shout the most about maintaining the status quo, are *ignorant of their own ignorance* about a proposed new paradigm. They’ve not studied the paradigm in detail, and likely might not even have the requisite training and experience even to make judgments. Many scientists have super-specialized: They know more and more about less and less, until ultimately they know everything about nothing. This doesn’t make innovative metaparadigms easy for them.

We have seen this lack of awareness repetitively in the disciplines of Psi and Consciousness Research, for example. This is, at times, particularly ironic, because, with respect, we suggest

a feasible unstudied conjecture: This disciplines are so multidisciplinary that few scientists in these specialties have been able to allocate even as much time to study them as they would to a regular bachelor's degree in a recognized university discipline, such as physics or psychology. This contrasts starkly with other disciplines, perhaps their own original one such as Physics or Psychology or Computer Science or even in English Literature. These same experts would never dare to comment in those specialties unless they had, at minimum, a PhD specializing in the specific area of the discipline being commented on.

So in disciplines like parapsychology, this might be one reason why the “*too wrong to be wrong*” level 1 statements of the IINCR are often particularly inappropriate: The critic should not be commenting at all or recognizing level 6 is more logical: *This is outside my discipline, so I don't understand it or haven't studied it. Let me suspend judgment.* That individual may be perceived as an “open-minded, appropriate skeptic” as opposed to the Level 1 individual who would be the “pseudo-skeptic” who will not evaluate for “feasibility” stopping at the “not falsifiable” level.

Consequently, two questions are raised:

- *How would a feasible model that explains all the varied the mechanisms of psi multidimensionally (as has recently been done¹²) produce change in the perception of psi?*
- *And would it raise the IINCR classification up a notch or two or five?*

But on the other hand, and very importantly, some paradigmatic models are simply incorrect and not feasible. And if they were falsifiable, they could be falsified using the correct approaches; yet most times, they are not falsifiable. Such justified rejection would reflect scientific success in maintaining the status quo: What is new, is not necessarily better. The data must support new findings. And the larger and more extreme the data, the stronger the new findings must be: They must be feasible, and not contradicted by the known data. This is why we need to add pieces to the jigsaw puzzle, but the pieces must fit appropriately.

Issue #9: Lower dimensional feasibility, absent falsification (LFAF)⁴⁴

It now becomes clear why we've proposed LFAF. Because falsifiability is usually limited to only 3S-1t, we proposed LFAF as our new model approach to the philosophy of science. LFAF recognizes that some elements cannot be falsified at this time in 3S-1t, yet there may be ample feasibility evidence in 3S-1t.⁸

This is why we propose the model of LFAF: Lower dimensional feasibility (usually 3S-1t), absent falsification is sometimes equivalent to using a jigsaw puzzle in 3S-1t and filling in the pieces that fit. However, we do not allow any contradiction where a piece of that jigsaw does not fit, because that would imply it is falsified or misinformation or contradicted by empirical evidence.^{8 65} So applying the feasibility jigsaw pieces, extends the falsifiable because it can incorporate incorrect jigsaw pieces.

By demonstrating the limitations of Popperian^{2, 30; 42} demands for the falsifiability of science in metadimensional realities (i.e., beyond 3S-1t), we apply this Lower Dimensional Feasibility—Absent Falsification (LFAF) approach when it is logically indicated.⁸

This is the key worth emphasizing: Because data at the higher dimensional levels cannot be completely represented in 3S-1t, the results present like single puzzle pieces in a whole, multidimensional (i.e., >3S-1t) puzzle. The data pieces are only there in part because they do not portray the multidimensional, just what is observed through the 3S-1t framework.^{10; 11} Consequently, conclusions may be feasible yet not falsifiable, or falsified in the traditional sense as they cannot be directly or completely represented in 3S-1t.⁸ There is a great deal that is covert or hidden, and not directly expressed in our experiential 3S-1t.

A word of caution: Our current laws of physics and observation can account for maybe 99.9% or even 99.99% of the world of reality that we experience.⁸ For these, we can usually apply Popperian falsification alone, though even then feasibility is useful in certain instances, such as in Medicine, where double-blind studies, though remaining the key to measure acceptance of research studies, are certainly limited, as indicated, in clinical practice.⁴³

Ironically, and importantly, when we apply the well-accepted principle of Karl Popper's falsifiability³⁶ to the validity of our current materialistic 3S-1t paradigm, some of the current conventional laws are falsified (perhaps within that tiny 0.01%).⁸ Such falsification is sometimes at the quantal level, and sometimes unexplained, but paradoxes occur that do not contradict our data, only making them ill understood conundrums. In physics, we cannot explain 'entanglement' and 'non-locality'.

At times, these unexplained elements in 3S-1t alone occur in Consciousness Research, for example, involving what to us, from our "restricted 3S-1t" framework⁹ would be regarded "relatively non-local"^{10; 11}. Yet, these might involve occasional "windows of visualizing" through that altered states of consciousness and applying a different set of dimensional domains as our framework for that state.⁶⁶ Their occurrence exemplifies contradictions that simply should not exist if it would be correct that the current 3S-1t paradigm truly reflected all of existence. Alternatively, the contradictions or unknown element may simply be interpreted as *unexplained conundrums that defy explanation* when they may well be solved by another paradigm. It is insufficient that laureate Feynman might have shrugged his shoulder and recognized that there are some inexplicable quantum enigmas.⁴¹ *Such mysteries demand solutions for us to continue scientific progress.*

There are some obvious empirically based prejudicial examples, that were initially unexplained and not falsifiable such as the origins of hypnosis, electricity, X-rays, meteorites, sterilization of bacteria preventing illness, the round Earth, Earth revolving round the sun, Einsteinian relativity, warping of reality, splitting the atom, and psi.^{6, 53} They all

⁹ Restricted because we cannot even experience all of 3S-1t.

would presumably in their times have been dogmatically rejected as “*too false to be false*”. Only their later *post hoc* justification supported the Popperian view because they were then falsifiable or replicated³⁶: They simply moved from metaphysics to real science. With LFAF, they would never have been metaphysical but applying real science (Table 9A).

Table 9A: Science or philosophy? Some pertinent terms.
<u>Meta-</u> : A prefix implying in the context used here: “broader higher level of order” e.g. Gödel used the term “metamathematics”. ³ This “meta” is different from “with, across or after”.
<u>Metaparadigm</u> : Broadest paradigm impacting all sciences, mathematics and philosophy (origin Neppe and Close, 2012). Alternative, more specific, improved term for “TOE”. ³
<u>Metaphysical</u> : A philosophical term for models or ideas that cannot yet be classified as scientific; metaphysics embodies the theoretical, conceptual, or speculative.
<u>Theory of Everything (TOE)</u> : A commonly applied, but ambiguous term for a complete explanatory model of reality conforming to the laws of nature. TOEs should seamlessly reconcile with all the major theoretical models and authoritative sources of all the sciences and mathematics. ³ TOEs are sometimes regarded as primarily philosophical, yet the original, limited meaning was in Physics. ^{3 r}

With LFAF, the metaphysical has instead transformed into the feasible pieces of the scientific jigsaw puzzle and can eventually move from lower levels of certainty, to potentially feasible science, and then onto falsifiable and replicated science.

LFAF sometimes allows creative explorations, metaparadigms and theories of everything to become legitimate creative scientific endeavors and not metaphysics.

We’ve understood that LFAF applies a much more versatile technique than Popper’s alone. It keeps Popperian principles³⁶, and also applies the Neppe and Close concepts of feasibility, which, in turn, adds to Popper. In LFAF, we recognize that the experiences of our lives are *relative* ones—relative to this experiential *restricted* 3S-1t. It is “restricted” because there are many other 3S-1t features that mankind does not experience (such as echolocation in dolphins, extended olfaction in dogs, and X-rays in machines). These elements might not be directly falsifiable, but they are, at least, feasible relative to our 3S-1t experiential reality.

Given our restrictions in experiencing all of 3S-1t, how much more so are the covert higher dimensional experiences? We can locate clues to these covert components because some tiny 3S-1t jigsaw puzzle pieces might be feasible and provide pointers for preliminary analysis. Sometimes we directly experience portions of these covert areas in certain altered states of consciousness, like meditation.^{8 25 12 6} This might change our world-view: Consequently, we might, when applying 11NCR, be a little softer in our critique: “*It’s obvious it has to be incorrect: We all know that that cannot be so*” (Level 4 of 11NCR) as contrasted with the starting position that cannot be, “*it’s too wrong to even be wrong*” (Level 1 of the 11NCR).

^r Nevertheless, applying metric comparisons to 24 “TOEs”, TDVP scores far the highest with a perfect score.⁸

By demonstrating the limitations of Popperian ³⁶ demands for the falsifiability of science in multidimensional realities (i.e., beyond 3S-1t), we therefore apply the LFAF (lower dimensional feasibility—absent falsification /falsified) approach when logically indicated. The challenge is sometimes daunting because in the multidimensional realities, something may never have been done before. We regard the principles of LFAF as key to motivating any scientific models.

To us, after six years of intense Neppe-Close collaborative study, interaction and work, involving thousands of hours of collaborations and between us, and a combined half-century prior to our meeting, we are pleased to be able to apply our metaparadigmatic, so-called “theory of everything” model of TDVP. We do so because TDVP appears to be a major example of LFAF—in fact, LFAF was developed as a necessity while TDVP was being developed. We could not have progressed with TDVP without LFAF. Yet, TDVP is certainly, based on objective measures, the best candidate for a “Theory Of Everything (TOE)”, a term which we prefer to call a “metaparadigm” because “TOE” to us, is an ambiguous and misinterpreted phrase. ³ So let’s briefly apply TDVP as an example of how LFAF can move from the creative and metaphysical to a metaparadigm.

**Issue #10: Moving from “creative thought” and the “metaphysical” to a “metaparadigm”:
Applying LFAF in reality and in TDVP as a TOE**

The Neppe-Close Triadic Dimensional-Distinction Vortical Paradigm (TDVP), in our opinion, illustrates the concept of metaparadigm and also applies and, at times, requires the principles of LFAF. Additionally, it provides support for LFAF because it demonstrates the importance of feasibility analyses of those portions of a so-called ‘jigsaw puzzle’ of little bits of information that are in 3S-1t, but reflect some aspect of the hidden other dimensions. Therefore another application of LFAF is allowing for creative ideation including proposing some theories of everything.

In Table 10A, we illustrate such an example: We list the mnemonic DICTUM, or more correctly DICTtUuM as some of these letters are duplicated.

<i>Table 10A: TDVP principles</i> ^{6 15; 67 12}
<i>DICTtUuM</i>
D imensions
I nfinity
C onsciousness
T riadic tethering of Space, Time and Consciousness Extent; Theory of Everything.
U nification, U nified Monism
M athematics

DICTIONUM epitomizes the key features of this TDVP model. Consciousness is always the key, and the dimensions of consciousness are inseparably linked (tethered) dimensionally to Space and Time. Everything in reality—both the quantized finite and the continuous infinite that contains that finite—is unified. This results in the philosophical mind-body theory of *Unified Monism*. A great deal of TDVP can be demonstrated by applying appropriate mathematics. Importantly, we could not have developed LFAF without outlining the appropriate extension of scientific method that we've called TDVP.

We've written extensively about the TDVP model in many publications⁸, with the most recent even showing how it can feasibly provide mechanisms for every described form of psi.¹² So, TDVP has moved from the theoretical to the testable, and now to the practical applications of another science (Consciousness Research)¹². Frequently, this includes mathematical derivations. In one recent paper, for example, twenty hypotheses were tested and demonstrated.⁶

But the key here is not TDVP. Instead, it is to illustrate how LFAF allows what may be creative thought to be incorporated into science whereas previously it was not—it would have been non-provable and therefore regarded as “metaphysical”. So, LFAF extends metaparadigmatic models and potentially extends creative ideas to the scientific realms. But moreover, reciprocally the model of LFAF developed as a consequence of this metaparadigm (TDVP).

Issue #11: Re-examining the nature of reality

The nature of reality is very complex. Consequently, examining any areas such as science or LFAF or dimensions or TDVP that bear upon reality, will also be complex (Table 11A). Reality is different for everyone, but there are large portions such as six million watching a sports game on television, that have commonalities, hence common reality is one kind of reality we *experience* overtly. On the other hand, our experience is only a small part of what may be our *existence*. What we don't experience may be *covert*, but still could feasibly *influence* our experiences but surreptitiously like in subliminal advertising which may *impact* the contents of all our physical and psychological experiences in our *restricted 3S-1t*.

Reality includes our overt experience in 3S-1t. Though individualized and idiosyncratic, at times, the consensus of millions watching the Super Bowl together still, even then, may result in interpretations that are subjective and different for every individual. And beyond that overt experience, we speculatively argue that the covert existence might sometimes reflect some common but unitary discrete quantized pieces of the finite being embedded in a continuous infinite. Is this a feasible preliminary scientific proposal? Your choice!

Similarly, at what point do our windows of subjective experience end as a science? And conversely, where does the speculative—and therefore the metaphysical—begin? These concepts are examined briefly in Table 11A.

Table 11A Reality experience and existence concepts

<u>Reality:</u>	All of what exists. The <i>infinite and metafinite subrealities</i> make up an indivisible holistic unit. In TDVP, a sub-hypothesis is that this discrete metafinite is likely <i>embedded</i> in the continuous infinite. In sentient beings, reality is subjective, perceived or experienced.
<u>Common reality</u>	Common (or Consensual) reality may be verified independently by a majority of conscious observers. Much of reality is hidden so that what exists is far greater than this <i>common reality</i> . Reality requires the inseparably tethered components of S, T and C and conforms to natural law.
<u>Covert:</u>	Hidden realities are covert. For living humans, it is everything except the overt “restricted 3S-1t”. We can interpret little pieces of this covert reality as a jigsaw puzzle in restricted 3S-1t. But though covert, this level of reality still is likely important in our day to day living realities.
<u>Existence:</u>	Everything that exists, covert and overt. In TDVP, we postulate this involves everything in reality, with infinity embedding the metafinite.
<u>Experience</u>	What we can directly observe in our dimensional domain. In living humans this is limited to “restricted 3S-1t” only. In other dimensional domains, it depends on the framework of that observer.
<u>Overt</u>	the reality we can experience: restricted 3S-1t; not covert.

Issue #12: The summation: What science is all about.

We put all these issues together.

There are fundamental differences, from approaching a methodology that is scientific, to the philosophy of science approach which includes LFAF, to recognizing a key potential role of mathematical derivations, to allowing for extending ideas from the falsifiable to the feasible and beyond, to multidimensional frameworks, to applications of what is feasible in Medicine, and to conundrums in physics such as entanglement, and to psi¹² such as in the relative non-locality context. These all are ways of approaching “science”. The concept of what constitutes “science” must be clarified.

In this paper, we’ve shown that “feasibility” allows us to apply far more than we could before: Effectively, science might be difficult to define because it’s not a unitary concept: We argue that science must be conceptualized in a multi-axial manner (Table 12A). On the one axis is our methodological approach to problems, on another axis is the application of LFAF, and on the third axis is the appropriate role of mathematics and logic in applying the empirical, inferred, observed or phenomenological information, such that mathematicologic is not only distinct from science, but part of science.

Table 12A: Extending the multiaxial definitions of science

<i>Approach</i> to problems	Extend the current approach to include feasibility.
Requirements of <i>proof</i>	Philosophy of science requires LFAF.
<i>Mathematical</i> integration	Apply further appropriate feasible and falsifiable techniques.

We conclude showing the value of our twelve headers. In each, we see the roles not only of falsifiability which is sometimes unattainable; but we also ensure that we look at what is feasible.

We recognize that what is feasible is possibly often a level of proof below falsifiability; and, yet, we understand too that sometimes, what is feasible is far more pertinent in practical living, as in Medical practice, than demonstrating replication of data and that falsifiable data is not falsified. The two are not parallel ideas but again part of that multi-axial spectrum that is science.

Feasibility makes scientific endeavors more complete and allow us to sometimes not know all the truth but, at least, paste in legitimate jigsaw puzzle pieces, adding them randomly or in specific places. Indeed, we can now better understand the twelve issues we've discussed:

- The conventional Scientific Methodological Approach has limitations and requires additions to become more complete.
- This means the Philosophy of Science Approach must be amplified to include what is feasible, too.
- Specifically feasibility would make such Philosophy of Science approaches more versatile.
- Mathematics is not just an isolated discipline to calculate by: math certainly helps there, but we regard it as an essential part of reality becoming more comprehensible and approaches being more feasible and proven.
- Consequently, the axiomatic basis of mathematical logic must be expanded to make extend our approach to science.
- The amplifications of logical scientific data approaches include such esoteric techniques as the calculus of distinctions and dimensionometry, if need be, using feasible pieces of our 3S-1t jigsaw.
- Replicability remains a key issue in science, but often we can only replicate if the exact experimental set-up exists: Consequently, meta-analyses may be useful to dilute out confounding factors.
- These factors imply that the fundamental concepts of science should be re-examined; Science is not all it is made out to be—there are limitations.
- Extensions of science require the appropriate extensions of techniques: lower dimensional feasibility, absent falsification (LFAF) is critical, in that regard.
- LFAF can be applied to examining Theories of Everything or metaparadigms reflecting reality. The model of TDVP, from which LFAF thinking derived, is a prime example.
- Extending science allows us to further analyze the nature of reality.

- These factors allow us to apply this perspective for what science is all about.

Four final areas of emphasis are apposite to conclude these comments:

1. **The value of mathematics:** As Eddington emphasizes, “*the mathematics is not there, till we put it there*”.¹⁴ The further adaptation, as needed, of mathematical logic, of itself requires new ways of theorizing so that extra dimensions and pertinent distinctions can be incorporated.
2. **Porous fish-nets:** Yet, we should also go beyond mathematics to the empirical. Eddington’s fish-nets¹⁴ must be recognized as having their own limitations. They cannot be regarded as reflecting all of what our current science should be utilizing. There are gaping holes in conventional science, holes that can and should be feasibly evaluated. These holes may allow us to appreciate more the mechanisms of psi, to approach the relatively non-local scientifically, and to recognize the value of assessing some results with an awareness of the difference between our 3S-1t *experience* and the broader *existence* in the finite and the infinite.
3. **The versatility of LFAF:** We now can recognize the value of LFAF. This involves identification of the current limitations of our scientific approaches, definitions, methods and concepts. We must realize the necessity to amplify knowledge when we need to. This way we can broaden our perspectives, extend science appropriately, allow the creative to merge with the scientific, and move to the 21st century.
4. **The jigsaw collaboration:** Pieces of the jigsaw puzzle add to the creativity of our endeavors to understand more about *reality*. We seldom have the complete picture, and even though science is necessarily progressing we can always put in little extra pieces into our creative understanding. That should allow future scientists to progress even more, and reflect another major property of science, namely *scientific collaboration*. This is a major contribution of feasibility for science. Applying LFAF helps us all not only now, but in future generations.

References:

1. Neppe VM, Close ER: *Reality begins with consciousness: a paradigm shift that works (First Edition)* 1 Edition. Seattle: Brainvoyage.com, 2012.
2. Popper KT: *The logic of scientific discovery*. London and New York: Routledge / Taylor and Francis e-Library, 2005.
3. Neppe VM, Close ER: Brief glossary of key terms in *Reality begins with consciousness: a paradigm shift that works (5th Edition)*. Edited by. Seattle, WA: Brainvoyage.com. pp. lxiv-lxxiv 2014.
4. Neppe VM, Close ER: *Reality Begins with Consciousness (RBC) — Glimpses and Glossary* 2nd Edition. Seattle, WA: Brainvoyage.com, 2014.
5. Close ER, Neppe VM: The seventh conundrum: the mathematical derivation of the Cabibbo mixing angle in fermions. *IQNexus Journal* 7: 2; 41-43, 2015.
6. Neppe VM, Close ER: How some conundrums of reality can be solved by applying a finite 9-D spinning model. *IQNexus Journal* 7: 2; 7-88, 2015.

7. Close ER, Neppe VM: The Cabibbo mixing angle and other particle physics paradoxes solved by applying the TDVP multidimensional spin model. *IQNexus Journal* 14: 1; 13-50, 2014
8. Neppe VM, Close ER: *Reality begins with consciousness: a paradigm shift that works (5th Edition)* Fifth Edition. Seattle: Brainvoyage.com, 2014.
9. Close ER, Neppe VM: Mathematical and theoretical physics feasibility demonstration of the finite nine dimensional vortical model in fermions. *Dynamic International Journal of Exceptional Creative Achievement* 1301: 1301; 1-55, 2013.
10. Neppe VM, Close ER: Relative non-locality - key features in consciousness research (seven part series). *Journal of Consciousness Exploration and Research* 6: 2; 90-139, 2015.
11. Neppe VM, Close ER: The concept of relative non-locality: Theoretical implications in consciousness research. *Explore (NY): The Journal of Science and Healing* 11: 2; 102-108, [http://www.explorejournal.com/article/S1550-8307\(14\)00233-X/pdf](http://www.explorejournal.com/article/S1550-8307(14)00233-X/pdf) 2015.
12. Neppe VM, Close ER: Explaining psi phenomena by applying TDVP principles: A preliminary analysis *IQNexus Journal* 7: 3; 7-129, 2015.
13. Kuhn T: *The structure of scientific revolutions* 1st Edition. Chicago: Univ. of Chicago Press, 1962.
14. Eddington A: *The philosophy of physical science*. Ann Arbor, MI: University of Michigan, 1938 (republished 1958).
15. Close ER, Neppe VM: Specific challenges involving the Close and Neppe research: The fourth conundrum: applying the Triadic Dimensional Distinction Vortical Paradigm (TDVP) constructs in our dimensional calculations. *IQNexus Journal* 7: 2; 31-33, 2015.
16. Neppe VM, Close ER: A Proposed Theory of Everything that works: How the Neppe-Close Triadic Dimensional Distinction Vortical Paradigm (TDVP) model provides a metaparadigm by applying nine-dimensional finite spin space, time and consciousness substrates and the transfinite embedded in the infinite producing a unified reality. *IQNexus Journal* 16: 3; 1-54, 2014.
17. Neppe VM, Close ER: The Triadic Dimensional Distinction Vortical Paradigm (TDVP): The nine-dimensional finite spin metaparadigm embedded in the infinite *Dynamic International Journal of Exceptional Creative Achievement* 1401: 1401; 4001-4041, 2014.
18. Neppe VM, Close ER: TDVP: a paradigm shift that works —how the Triadic Dimensional Distinction Vortical Paradigm challenges conventional scientific thinking and explains reality. *Telicom* 27: 1; 24-42, 2014.
19. Smullyan R: *Gödel's incompleteness theorems*. Oxford: Oxford University Press, 1991.
20. Berto F: *There's something about Gödel: the complete guide to the incompleteness theorem*. New York: John Wiley and Sons, 2010.
21. Bauer H: Misleading notions about science and their consequences. *WISE journal* 4: 2; 30-36, 2015.
22. Einstein A: *Relativity, the special and the general theory* 15 Edition. New York: Crown Publishers, 1952.
23. Close ER: *Infinite continuity: a theory integrating relativity and quantum physics*. Los Angeles: Paradigm Press, 1990.
24. Einstein A, Podolsky B, Rosen N: Can quantum-mechanical description of physical reality be considered complete? *Phys. Rev.* 47: 10; 777-780, 1935.
25. Neppe VM: Phenomenological consciousness research: ensuring homogeneous data collection for present and future research on possible psi phenomena by detailing subjective descriptions, using the multi-axial a to z SEATTLE classification. *Neuroquantology* 9: 1; 84-105, 2011.
26. Palmer J, Neppe VM: A controlled analysis of subjective paranormal experiences in temporal lobe dysfunction in a neuropsychiatric population. *Journal of Parapsychology* 67: 1; 75-98, 2003.
27. Palmer J, Neppe VM: Exploratory analyses of refined predictors of subjective ESP experiences and temporal Lobe Dysfunction in a neuropsychiatric population. *European Journal of Parapsychology* 19: 44-65, 2004.
28. Neppe VM, Palmer J: Subjective anomalous events: perspectives for the future, voices from the past, in *Parapsychology in the 21st century: essays on the future of psychical research*. Edited by Storm L, Thalbourne M. Jefferson, NC: MacFarland. pp. 242-274 2005.

29. Neppe VM, Close ER: On Non-locality I: Relative non-locality. *Journal of Consciousness Exploration and Research* 6: 2; 90-96, 2015.
30. Popper K: *Conjectures and refutations*. London: Routledge and Keagan Paul, 1972.
31. Close ER, Neppe VM: The eighth conundrum: angular momentum and intrinsic electron spin. *IQNexus Journal* 7: 2; 44-45, 2015.
32. Close ER, Neppe VM: The eleventh conundrum: The double Bell normal curve and its applications to electron cloud distribution *IQNexus Journal* 7: 2; 51-56, 2015.
33. Close ER, Neppe VM: The ninth conundrum: two different solutions to electron rotation *IQNexus Journal* 7: 2; 46-49, 2015.
34. Close ER, Neppe VM: The tenth conundrum: weak universality based on the 9D findings. *IQNexus Journal* 7: 2; 50, 2015.
35. Close ER, Neppe VM: The Calculus of Distinctions: A workable mathematicologic model across dimensions and consciousness. *Dynamic International Journal of Exceptional Creative Achievement* 1210: 1210; 2387 -2397, 2012.
36. Smythies JR: *The walls of Plato's cave*. Aldershot: Avebury Press, 1994.
37. Close ER: Appendix B: 1965 Proof of Fermat's Last Theorem, in *The Book of Atma*. Edited by. New York: Libra Publishers. pp. 93-99 1977.
38. Close ER, Neppe VM: The sixth conundrum: theoretical knowledge on deriving the Cabibbo angle. *IQNexus Journal* 7: 2; 39-40, 2015.
39. Neppe VM, Close ER: Translating some conundrums of the universe by applying a 9 dimensional spinning model of finite reality: References. *IQNexus Journal* 7: 2; 84-88, 2015.
40. Neppe VM, Close ER: A Perspective overview of the seventeen conundrums: Abstract *IQNexus Journal* 7: 2; 8-10, 2015.
41. Feynman RP (ed.). *The Feynman lectures on physics*. USA, Addison-Wesley, 1965.
42. Popper K: *A world of propensities* London: Thoemmes, 1990.
43. Neppe VM: Double blind studies in Medicine: perfection or imperfection? *Telicom* 20: 6 (Nov. -Dec); 13-23., 2007.
44. Neppe VM, Close ER: The second conundrum: Falsifiability is insufficient; we need to apply feasibility as well Lower Dimensional Feasibility, Absent Falsification (LFAF) as a scientific method *IQNexus Journal* 7: 2; 21-23, 2015.
45. Neppe VM, Close ER: The sixteenth conundrum: The general immediate implications of a nine dimensional reality *IQNexus Journal* 7: 2; 79-80, 2015.
46. Spottiswoode SJP: Apparent association between effect size in free response anomalous cognition experiments and local sidereal time. *Journal of Scientific Exploration* 11: 2; 109-122, 1997.
47. Rosenthal R: On the social psychology of the psychological experiment: The experimenter's hypothesis as unintended determinant of experimental results. *American Scientist* 51: 268-283, 1963.
48. Neppe VM: The experimenter effect in medical research. *South African Medical J* 62: 3; 81, 1982.
49. Neppe VM: Why parapsychology is amongst the most important of the sciences, in *In search of psi*. Edited by Rock AJ, Storm L. Ashland, OH: Pari Publishing. pp. 225-227 2014.
50. Neppe VM: Why parapsychology is amongst the most important of the sciences. *Australian Journal of Parapsychology* 5: 1; 4-22, 2005.
51. Truzzi M: On the extraordinary: An attempt at clarification. *Zetetic Scholar* 1: 1; 11, 1978.
52. Neppe VM, Close ER: *Reality Begins with Consciousness (RBC)—Key Features* 2nd Edition. Seattle, WA: Brainvoyage.com, 2014.
53. Bauer H: *Dogmatism in science and medicine: How dominant theories monopolize research and stifle the search for truth*. New York: McFarland, 2012.
54. Popper K: Replies to my critics, in *The Philosophy of Karl Popper, Part II*. Edited by Schilpp PA. Illinois: The Open Court Publishing Company. 1974.
55. Barber B: Resistance by scientists to scientific discovery. *Science* 134: 3479; 596-602 1961.

56. Press release). Retrieved 3 October 2005, from http://www.nobelprize.org/nobel_prizes/medicine/laureates/2005/press.html. 2005.
57. Koestler A: *The Sleepwalkers*. London: Hutchinson, 1959.
58. Price EA: Two apparently reciprocal telepathic dreams and suggestions for a new approach to the study of spontaneous cases. *Parapsychologica* IV: 9 1970.
59. Neppe VM: Revisiting survival 37 years later: Is the data still compelling? *Journal of Spirituality and Paranormal Studies* 33: 3; 123-147, 2010.
60. Planck M: *Max Planck: Scientific Autobiography and Other Papers*. New York: Harper 1949.
61. Schrödinger E: *What is life? with mind and matter and autobiographical sketches*. Cambridge: Cambridge University Press, 1992.
62. Crichton M: *Aliens cause global warming: A Caltech lecture* in Caltech Michelin Lecture. Caltech.2003.
63. Neppe VM: *How attorneys can best utilize their medical expert consultant: A medical expert's perspective*. Second Edition. Seattle: Brainquest Press, 2008.
64. Peierls R: Wolfgang Ernst Pauli. 1900-1958. *Biographical memoirs of Fellows of the Royal Society* 5: Feb; 174-192, 1960.
65. Close ER, Neppe VM: Translating fifteen mysteries of the universe by applying a nine dimensional spinning model of finite reality: A perspective, the standard model and TDVP. Part 1. *Neuroquantology* 13: 2; 205-217, 2015.
66. Neppe VM, Close ER: Limitations of the standard model of physics. *Dynamic International Journal of Exceptional Creative Achievement* 1201: 1201; 2001-2010, 2012.
67. Neppe VM, Close ER: The third conundrum: How the core dimensional calculations in the Neppe-Close Triadic Dimensional Distinction Vortical Paradigm (TDVP) contributes to a workable model of reality. *IQNexus Journal* 7: 2; 24-30, 2015.

Change of Strategy in Cancer Care Management: Cancer Immunotherapy a Major Breakthrough Leading to a Paradigm Shift

by: Gaston Naessens, ND (Naturopathic Doctor)
Jacinte Levesque Naessens, B.S., B.E., M.S., TCMD



Historical background: From the War against Cancer...

The “War against cancer”, as it textually appears in the National Cancer Act signed by President Nixon in 1971, has been driven by the assumption that “magic bullets” exist to eradicate one day this dreadful disease^(1,2).

In the last 44 years, the battle has been waged around the world in laboratories, in hospitals, in our own homes and bodies. But earlier this year, Harold Varmus, the past director of NCI, requested that this uncanny metaphor be discarded from our vocabulary³. Colin Macilwain, in a reflexion of his, “Change the Cancer Conversation” published in *Nature*, concludes that this vision has definitely run off course^(2,3).

Until recently, the main weapons deployed against cancer were surgery, radiation, and chemotherapy treatments, along with their associated risks and/or cause adverse side effects. “Although some forms of cancer yield to these therapies, not all do, and thus mortality remains high”^(4,5,6).

...to cancer immunotherapy, or how to nurture the immune system

To that list we now add a fourth weapon, or as we should now say, a new method: cancer immunotherapy, which aims to harness the body’s own immune system.

“Constructed over years, decades, it has begun to demonstrate such promising results in cancer patients that we (The Science Journal) selected it as the breakthrough of the year 2013.”⁽⁴⁾

“We believe that 2013 marks a significant moment in cancer history, and today’s achievement merit recognition and celebration, even if uncertainties remain.”⁽⁴⁾

Conventional Science agrees a change of strategy addressing cancer treatment is highly needed⁽²⁾.

The tumor-based model has reached its limits. Genomics have not yet met all the expectations. The person-based model is making its way.

Gaston Naessens, a pioneer in cancer immunotherapy

What is seen as a breakthrough today by science, Gaston Naessens, as a true pioneer in his field, had already proposed back in the 1950’s.

Naessens always viewed cancer as a weakness of the immune system, therefore calling for cancer immunotherapy. His microscopic observations of live blood on mammals in the 1950’s lead him to develop a new biological theory which he called Somatidian Orthobiology*.

* Somatidian Orthobiology is the reading of live blood through the knowledge and understanding of the somatids, a live particule in blood of mammals that evolves into various forms as a witness of the state of the natural defenses. (Including the immune system)

In 1962, 53 years ago, [he obtained in France a patent](#) on an anti-cancerous vaccine (a product called Anablast⁷). Over the years, he was able to design other non-toxic health products capable of addressing the natural defenses including the immune functions.

His latest nontoxic immune modulator, 714X, is a highly potent anti-inflammatory compound designed to restore the somatidian cycle.

Since 2003, 4 patents have been issued for USA (2003), EC (2005), Canada (2010), Japan (2014) Triméthylaminohydroxybicycloheptane chloride (714X).

Also, 714X has also been integrated in the Special Access Program of the Canadian Health Agency, Health Canada, since December 1989⁸.

From controversy to collaboration

So much controversy was fuelled throughout the years because Naessens then innovative vision, seen as nearly heretic, was so different to what oncology proposed until recently. But things are changing drastically and his vision is making its way.

“It is the determination, faith and resolve of the putative inventor which keeps him on track until the breakthrough is made.”⁹

Naessens idea has been verified by potent clinical results and now in 2015, cancer immunology is not only considered a breakthrough by mainstream oncology, but adds up as the 4th arm of clinical oncology⁽⁵⁾.

Now that cancerology is at a crossroads, hopefully collaboration rather than competition will be possible. The excitement about cancer immunotherapy generated by the annual American Society Clinical Oncology (ASCO) meeting in Chicago early in June 2015 demonstrates the urgent need to open up on innovative ways to address cancer¹⁰.

Let's hope that this will create a bridge between the actors of non-conventional medicine (naturopathic approach, person-based model) with conventional medicine (evidence based-medicine). Let's seize the opportunity of instilling a balance between these two medical philosophies^(11,12,13).

What differentiates Gaston Naessens work with mainstream medicine?

1. His proposals of new health products to modulate the immune system are designed to be non-toxic. Naessens convictions are strong against genetically engineered treatments or toxic products that weaken the immune system. The immune system is so complex and fine-tuned that it can't be bypassed. The body has the capability to harmonise itself. The wisdom of biology cannot be fooled.
2. Gaston Naessens visions cancer as a systemic condition (a weakness of the natural defenses, including some aspects of the immune system) that pre-exists months prior to

being locally measurable on a cellular level (confirmed in pathology). For Naessens, cancer is not a local disease that spreads out, but a systemic condition that leads to cancerisation in a specific tissue or organ.

Clinical results over the last 45 years show that surgery, chemotherapy or radiotherapy (alone or combined) are non-conclusive attempts to restore definitive biological balance^(14,4,6).

3. Naessens endorses through his clinical and microscopic observations the basis of neuro-psycho immunology as proposed years back by Dr. Carl Simonton¹⁵. No earlier than in 2008, the Scientific American Journal showed there was a link between the chemokines and the neurotransmitters that do cross the blood brain barrier^(16,17,18).

This supports strongly the connection between our physiological systems and our emotional expressions. Positive emotions do influence directly extra cellular and/or cellular activities, and vice-versa. Negative emotions may not be causal but are certainly a trigger to halt the proper functions of the immune system.

This new understanding will change the approach of cancer care management. This is not about waging a war against cancer but rather to find ways to nurture the immune system^(19,20).

The good news is that previous tools of conventional cancer management together with immunotherapy can be done simultaneously to the benefit of the patient.

This is also true for Naessens proprietary blend, 714X, that can be taken alone or in combination with conventional cancer treatments depending on circumstances and personal choices.^(21,22,13)

Conclusion

Even if treatments in conventional cancerology have not been fully successful^(23,24,14,5,4) and that genomics have not yet met our expectations, medical research should not give up on a quest for better understanding of what has become the number one killer of all times^(25,26).

An unprecedented journey is about to begin in medicine and is as critical today as when Dr Ignaz Philip Semmelweis forced doctors to wash their hands. Together, by understanding the body's natural ability to maintain and heal itself, we will empower human beings to stimulate their inner healing power, thus establishing solid roots for primary prevention. This paradigm shift can jump-start the most important medical revolution of the century.

All is in place. Let's make it happen.

About the authors:

Gaston Naessens is the president founder, CEO of Cerbe inc, a private laboratory specialized in fundamental research in biology, including hematology.

Cerbe is also the manufacturer of **Triméthylaminohydroxycycloheptane chloride (714X)** for which 4 patents have been granted [2003 (USA), 2005 (Europe), 2010 (Canada) and 2014 (Japan).]

Jacinte Levesque Naessens is the director general of Cerbe Distribution inc., a privately owned company addressing health care consumers requesting information on 714X, an immune modulator designed for degenerative disorders

How to reach us:

Phone : 819 564-7883

E-mail: info@cerbe.com

Acknowledgement :

Gaston Naessens and Cerbe inc has been encouraged throughout the years by the philanthropic foundation McDonald Stewart Foundation, located in Montréal Quebec (1972-2014).

- ¹ RENNIE, John, RUSTING Ricki. "Making Headway Against Cancer", *Scientific American: What you Need to Know About Cancer*, September 1996, p. 56-167.
- ² GATENBY, Robert A. "A Change of Strategy in the War Against Cancer", *Nature*, vol 459, May 28 2009, p.508-209.
- ³ MACILWAIN, Colin. "Change the Cancer Conversation: World View Opinion", *Nature*, vol 520, April 2, 2015.
- ⁴ MCNUTT, Marcia. "Cancer Immunotherapy Editorial", *Science*, vol 342, December 20, 2013, p. 1417.
- ⁵ FRANKEL-COUSIN, Jennifer. "Breakthrough of the Year: Cancer Immunotherapy News Focus", *Science*, vol 342, December 20, 2013, p. 1431-1433.
- ⁶ MOSS, Ralph W. *Questioning Chemotherapy*, New York, Equinox Press, 1995, 2014 p.
- ⁷ [Cabinet Mee SAUTTER HARLÉ & LÉCHOPIEZ, Ingénieurs conseils et propriété industrielle. « Sérum et vaccin anticancéreux ». Brevet Spécial de Médicament, n°1115, Paris, 1962.](#)
- ⁸ KAEGI, Elizabeth. MB, "Unconventional Therapies for Cancer: 714X", *Canadian Medical Association*, June 6, 1998, p. 158:1621-1624.
- ⁹ SPIER, Raymond E. "Peer Review and Innovation", *Science and Engineering Ethics*, vol. 8, issue 1, 2002, p.99-108.
- ¹⁰ American Society of Clinical Oncology Annual Meeting, *Illumination & Innovation*, 2015.
- ¹¹ DISPENZA, Joe. *You are the Placebo: Making Your Mind Better*, California, Hay House, 2014, 348 p.
- ¹² HAMILTON, David R. *How Your Mind can Heal Your Body*, California, Hay House, 2010, 263 p.
- ¹³ WEIL, Andrew. *Spontaneous Healing: How to Discover and Enhance your Body's Natural Ability to Maintain and Heal Itself*, New York, Knopf, 1995, 309 p.
- ¹⁴ NELSON, Roxane. *Palliative Chemo Worsens Quality of Life in Dying Patients*, JAMA Oncology (Published online July 23, 2015).
- ¹⁵ SIMONTON, Carl, MATTHEWS-SIMONTON, Stephanie, CREGHTON, James L. *Getting Well Again*, California, JP Tarcher Inc., 1978, 304 p.
- ¹⁶ ROSTÈNE, W., Mélik-Parsadaniantz, S. « De nouveaux messagers dans le cerveau », *Pour la Science*, n°369, Juillet 2008, p. 66-72.
- ¹⁷ ROSTENE, William et al. "Neurochemokines: A Menage a Trois Providing New Insights on the Functions of Chemokines in the Central Nervous System", *Journal of Neurochemistry* 118, September 2011, p. 680-694.
- ¹⁸ LEE, Sylvia, MARGOLIN, Kim. "Cytokines in Cancer Immunotherapy", *Cancers*, 2002, p. 3856-3893.
- ¹⁹ LIPTON, Bruce. *The Biology of Beliefs: Unleashing the Power of Consciousness, Matter & Miracles*, California, Hay House, 2005, 240 p.
- ²⁰ Braden, Gregg. *The Spontaneous Healing Of Belief Shattering the Paradigm of False Limits*, California, Hay House, 2009, 392 p.
- ²¹ WEISS, U. "Inflammation", *Nature*, vol 454, issue 7203, July 24, 2008 p. 427.
- ²² MEDZHITOV, R. "Origin and Physiological Role of Inflammation", *Nature*, vol 454, issue 7203, July 24, 2008, p.428-477.
- ²³ STRATTON, R. Michael, CAMPBELL, J. Peter, FUTREAL, Andrew. "The Cancer Genome", *Nature*, vol. 458, April 9, 2009, p.719-724.

²⁴ BAILAR III, J.C. "Cancer in Canada: Recent Trends in Mortality", *Chronic Dis Can*, 1992;13:Suppl: S2-S8.

²⁵ TOPOL, Eric. *The Creative Destruction of Medicine: How the Digital Revolution Will Create Better Health Care*, New York, Perseus Books Group, 2012, 303 p.

²⁶ BOUKARAM, Christian. *Le pouvoir anticancer des émotions*, Montréal, Les Éditions de l'Homme, 2011, 176 p.

THE STRUCTURE OF WATER

and

HOW PSYCHE ENTERS MATTER

by
Dr. Richard Alan Miller, c2015
www.richardalanmiller.com
www.oak-publishing.com

Part One

On The Nature of Water

To begin any discussion on the nature of water is to first recognize how it appears in nature. Water (H₂O) is the most abundant compound on Earth's surface, covering more than 70 percent of Earth's surface. In nature, it exists in both liquid, solid, and gaseous states.

It is in dynamic equilibrium between the liquid and gas states at standard temperature and pressure. At room temperature, it is a tasteless and odorless liquid, nearly colorless with a hint of blue (associated with the oxygen atom).

Many substances dissolve in water and it is commonly referred to as the universal solvent. Because of this, water in nature (and use) is rarely pure and some properties may vary from those of the pure substance. It is the only common substance found naturally in all three common states of matter.

It is essential for all life on Earth, and makes up to 78% of the human body.

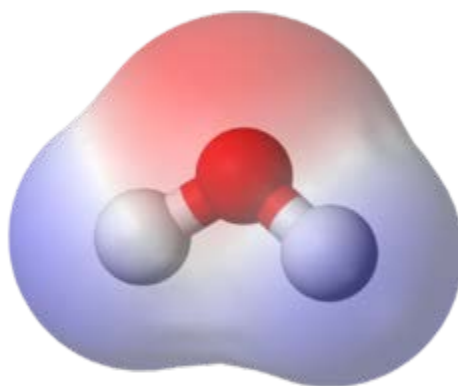

One of the more interesting aspects on the chemistry of water is that it is the smallest, yet most common molecule to have a dipole moment. In physics, the electric dipole moment is a measure

of the separation of positive and negative electrical charges in a system of electric charges, that is, a measure of the charge system's overall polarity.

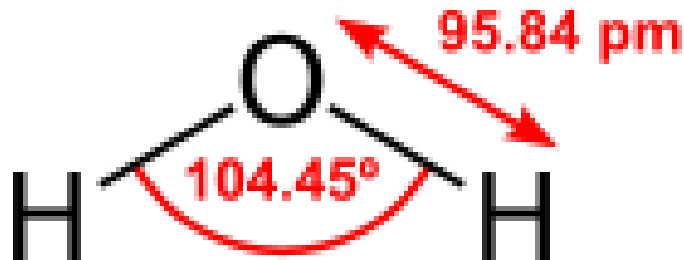

The two hydrogen molecules, combining with a single oxygen molecule, create this dipole. As such, it could be seen as the smallest door in physical space, going from one point in space-time to another. After all, a dipole moment is what determines the direction of electric flow, while creating a magnetic field around the molecule itself.

In modern physics, this concept is often referred to as a “dimensional gate,” going from one set of space-time coordinates to another. Water is the smallest known molecule with a dipole moment.

Ortho- and Para- Water - Molecular hydrogen occurs in two isomeric forms, one with its two proton spins aligned parallel (ortho-hydrogen), the other with its two proton spins aligned antiparallel (para-hydrogen). Each hydrogen molecule (H₂) consists of two hydrogen atoms linked by a covalent bond. An isomer is when this alignment goes either to the left or the right.

If we neglect the small proportion of deuterium and tritium which may be present, each hydrogen atom consists of one proton and one electron. Each proton has an associated magnetic moment, which is associated with the proton's spin of 1/2. In the H₂ molecule, the spins of the two hydrogen nuclei (protons) couple to form a triplet state known as ortho-hydrogen, and a singlet state known as para-hydrogen.

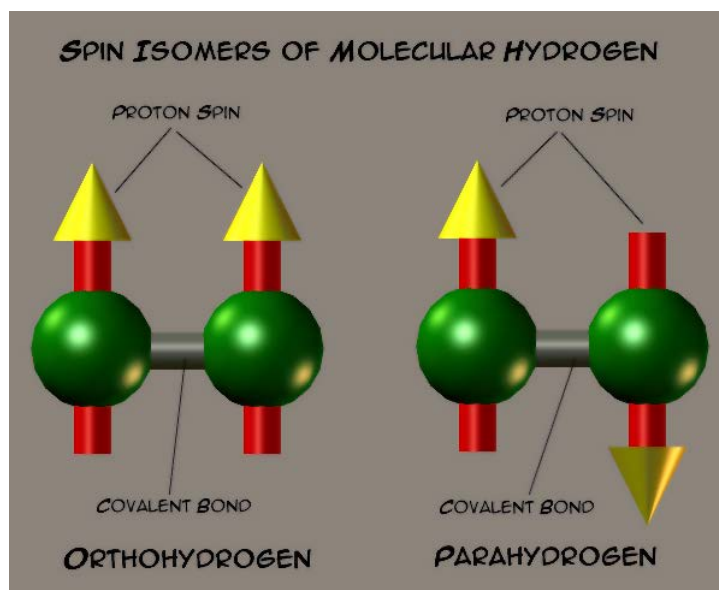

Para-hydrogen is in a lower energy state than is ortho-hydrogen. At room temperature and thermal equilibrium, thermal excitation causes hydrogen to consist of approximately 75% ortho-hydrogen and 25% para-hydrogen. After hydrogen is liquified, there is a slow spontaneous transition to a predominantly para- ratio, with the released energy having implications for storage.

The ratio between the ortho- and para- forms is about 3:1 at standard temperature and pressure - a reflection of the ratio of spin degeneracies. However if thermal equilibrium between the two forms is established, the para- form dominates at low temperatures (approx. 99.8% at 20 K)

The Isotopes of Water - Hydrogen (H) has three naturally occurring isotopes, sometimes denoted 1H, 2H, and 3H. Other, highly unstable nuclei (4H to 7H) have been synthesized in the laboratory but not observed in nature. The most stable radioisotope is tritium, with a half-life of 12.32 years.

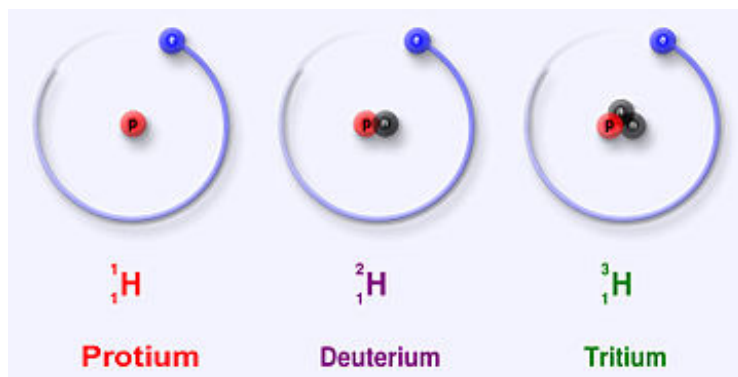

Hydrogen is the only element whose isotopes have different names that are in common use today. The ${}^2\text{H}$ (or hydrogen-2) isotope is usually called deuterium, while the ${}^3\text{H}$ (or hydrogen-3) isotope is usually called tritium. The symbols D and T (instead of ${}^2\text{H}$ and ${}^3\text{H}$) are sometimes used for deuterium and tritium.

Clustered Water Forms - In chemistry a water cluster is a discrete hydrogen bonded assembly or cluster of molecules of water. These clusters have been found experimentally or predicted in silico in various forms of water; in ice, in crystal lattices and in bulk liquid water, the simplest one being the water dimer $(\text{H}_2\text{O})_2$.

Ongoing academic research is important because the realization that water manifests itself as clusters rather than an isotropic collection may help explain many anomalous water characteristics such as its highly unusual density temperature dependence. Water clusters are also implicated in the stabilization of certain supramolecular structures.

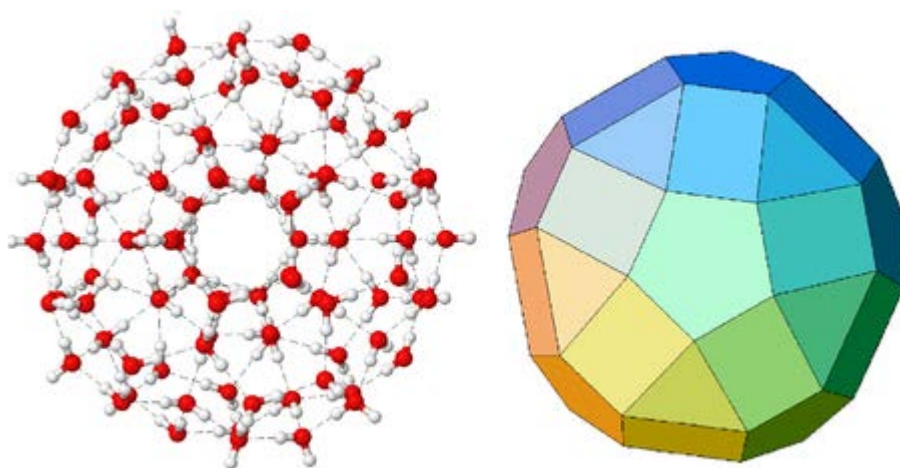

So little is understood about water clusters in bulk water that it is considered one of the unsolved problems in chemistry

The most common form today is called “activated water,” usually associated with a waterfall. The actual mechanism causes the water to structure as $H_7O_9^+$, plus a free radical ion (-). It is considered the healthiest form, and is why we often feel “refreshed” when near a waterfall.

This cluster form can be generated via a negative ion generator. Gilbert Ling, who was a pioneer in this field, discovered that water in human cells is not ordinary water (H_2O), but something far more structured and organized.

I began to think about water in the context of biology: if water inside the cell was ordered and structured and not bulk water or ordinary water as most biochemists and cell biologists think, then it is really important,...

Dr. Jerry Pollack

The Fourth Phase of Water: Beyond Solid, Liquid, and Vapor

This article was adapted from Dr. Richard Alan Miller's forthcoming book, *The Non-Local Mind in a Holographic Universe*, due out in the near future.

Dr. Richard Alan Miller
Physicist and Writer
www.richardalanmiller.com/ram/
www.oak-publishing.com

Coming Next:

Part 2: Jerry Pollack, and the Structure in Water

ELECTROPHOTONIC ANALYSIS OF COMPLEX PARAMETERS OF THE ENVIRONMENT AND PSYCHO-EMOTIONAL STATE OF A PERSON

Konstantin G. Korotkov

St. Petersburg Federal University of Information Technologies, Mechanics and Optics,
Russia

Korotkov2000@gmail.com

Introduction

Ecological state of the environment and its influence on the health and well-being of people is determined by the total set of parameters bio and techno-sphere. These include features and climate of the area, in particular, the level of solarization, the level of air pollution, the distribution of the electromagnetic fields, both natural and anthropogenic origin, and many other factors. As shown in recent years, a significant contribution is made by such heterogeneity of the earth's crust structure as discontinuous zones of tectonic disturbances and tensions, in particular, ancient buried rivers^{1,2}. In the period 1992-2005 in St. Petersburg, Russia, a large scientific team took a number of geological, geochemical, geographical and ecological surveys, correlating them with the health status of population. As a result, a statistically significant correlation between the level of disease in different areas of St. Petersburg and the presence of underground anomalies was demonstrated³. The influence of the electromagnetic field on the human health is widely discussed⁴, including the response of biological systems to perturbations of the electromagnetic field in the high frequency (HF) and very high frequency (VHF) bands through human activities⁵. The variety of factors and their dynamic nature requires the use of complex specialized methods that is not always available, even for well-equipped research centers. This makes the evaluation of hazards difficult even for large companies, not to mention the individual citizens. Meanwhile, a similar assessment is fundamentally important both at the design phase of new constructions, and in the analysis of the causes of poor health and increased incidence of people in certain climatic and geographical areas. Therefore, the actual challenge for engineering is to develop a low-cost device for informative comprehensive evaluation of the integral parameters of the ecological environment, which can be used both in a professional environment, and the civilian population.

EPI/GDV Technique

The Human Energy Field (HEF) is a highly sensitive reflection of the physical, emotional, and in some instances, the spiritual assessment of an individual. To measure this, data is obtained from the fingers of both hands and is converted into an HEF image using proprietary sophisticated software. This technology is predicated on the Gas Discharge Visualization (GDV) process. The results are interpreted based on the energy connection of fingers with different organs and systems via meridians that are used in acupuncture and traditional Chinese medicine. A promising method already utilized in sixty-two countries to great success is bioelectrography, based on the Kirlian effect. This effect occurs when an object is placed on a glass plate and stimulated with current; a visible glow occurs, the gas discharge. With EPI/GDV (electrophotonic imaging through gaseous discharge visualization) bioelectrography cameras, the Kirlian effect is quantifiable and reproducible for scientific research purposes. Images captured (BIO-grams) of all ten fingers on each human subject provide detailed information on the

person's psycho-somatic and physiological state⁶. The EPI/GDV camera systems and their accompanying software are currently the most effective and reliable instruments in the field of bioelectrography^{7, 8, 9, 10, 11}. EPI/GDV applications in other areas are being developed as well^{12, 13, 14, 15, 16, 17, 18, 19, 20}.

Through investigating the fluorescent fingertip images, which dynamically change with emotional and health states, one can identify areas of congestion or health in the whole system. Each generated fingertip photograph is analyzed by sector division, according to acupuncture meridians. Dr. Peter Mandel, in Germany²¹ over many decades, has developed this intricate and well-defined method of seeing into the entire body through the fingertips. EPI/GDV technique researchers created a diagnostic table based on years of their own clinical field-testing, the sector basis of which differs from that of Dr Mandel²².

The parameters of the image generated from photographing the finger surface under electrical stimulation creates a neurovascular reaction of the skin, influenced by the nervous-humoral status of all organs and systems. Due to this, the images captured on the EPI/GDV register an ever-changing range of states²³. In addition, most healthy people's EPI/GDV readings vary only 8-10% over many years of measurements, indicating a high level of precision in this technique. A specialized software complex registers these readings into parameters which elucidate the person's state of wellbeing at that time²⁴. The latest Bio-Well device is using all data processing via Internet (www.Bio-Well.com).

Monitoring the Environment

The Bio-Well device with a specially designed sensor called the "Sputnik antenna" is used to monitor the Energy of the Environment and its effects on emotional status. The "Sputnik antenna" is a specialized Bio-Well device that measures the energy of the environment in a room that enables you to see how it varies when people meditate, pray or listen to a presentation. The physical principle it is based on measuring the electrical capacitance of a space by using two connected resonance contours.

Schematic representation of the experimental setup is shown in Figure 1.

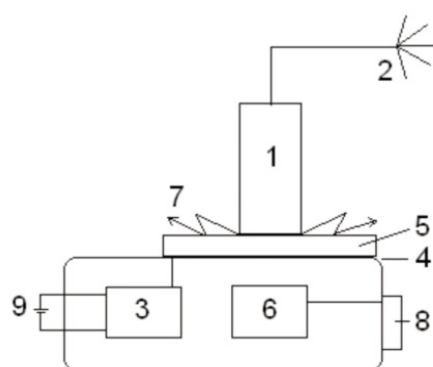

Fig. 1 The experimental setup. 1 - metal cylinder; 2 Antenna "GDV Sputnik"; 3 - high-voltage pulse generator; 4 - transparent conductive coating; 5 - transparent quartz electrode; 6 - video converter; 7 - glow; 8 - USB-drive; 9 - Power Supply

Titanium cylinder 15 mm in diameter connected to an antenna 2 is positioned on the quartz surface of the electrode 5, the reverse side of which is covered with a transparent conductive coating 4; from the generator 3 every 5 seconds a voltage in the form of a pulse sequence of up to 7 kV amplitude, 10 microsecond duration at a frequency of 1 kHz is applied to the coating. Ultraviolet light 7 is transformed by optoelectronic system 6 in a series of images, which are analyzed in a computer. Experimental system in case of being in the room can be represented as an equivalent circuit of the connected LC circuits (see Fig. 2).

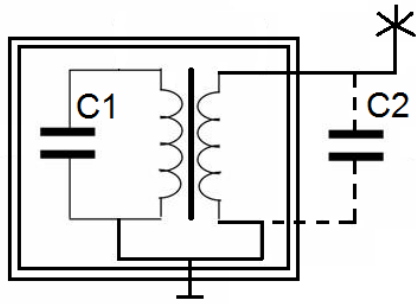

Fig. 2 Equivalent circuit diagram of the experimental setup, where C1 corresponds to the capacity of the electronic circuit of the Bio-Well device, C2 - the equivalent capacitance of the antenna in the premises.

Discharge develops due to displacement currents between the antenna 2 and grounded or conductive objects in the environment. Depending on the availability of fields of different nature in the environment, the chemical composition of the air and the state of the conductive objects (which includes humans), conditions of electromagnetic wave propagation in space are changing, therefore the currents in the system are redistributed, thus influencing parameters of the glow. Thus, this experimental system can react to changes in the electrical capacitance of the space surrounding it and the presence of the conductive objects. Changes in the functional state of the human body leads to a change in the impedance of the body, the field distribution around the body, the chemical composition of the ambient air due to exhaled air and emissions of endocrine substances through the skin.

Data processing was carried out in a specially designed software (www.Bio-Well.com). For analysis both the absolute values of the parameters and their standard deviations in the series were taken into consideration. During the measurements the control of the environment parameters: relative humidity, temperature and pressure was undertaken. In some cases, available through the Internet geophysical parameters: phases of the moon, geomagnetic situation on the day of measurement and a number of other parameters were taken into account as well.

Sputnik sensor may be useful for the following purposes:

1. Testing different places in a search for locations that are calm or contain turbulent energy.
2. Testing the energy status of different sites that are significantly affected by the position of the sun, moon, season or time of the year, etc.
3. Measuring the energy in the Places of Power – both natural and man-made, such as temples and other houses of worship, sacred places, ancient cities, etc.
4. Testing Geoactive Zones, in particular, Geopathic Stress Zones²⁵.
5. Detecting the influence of emotions, meditation and focused attention on the parameters of the device.

It has long been observed that people feel differently depending on environmental factors that may include temperature, humidity, atmospheric pressure and geographic location. There are some places where you sleep like a baby, have wonderful dreams and wake up full of energy. But there are others where sleeping is disrupted, fatigue is frequent and there is increased susceptibility to illness. Western science has no explanation for this other than it represents a confluence of geomagnetic influences, subterranean anomalies, hollows, water streams, natural and industrial atmospheric gases; gases, electromagnetic fields, and especially solar and cosmic emanations. It has been practically impossible to distinguish between all these factors or to determine what each contributes, so our ability to measure the cumulative effect at any particular place can best be described as primitive and rudimentary.



Figure 3. Bio-Well device and a "Sputnik" sensor.

The software allows to perform automatically statistical analysis of a time series data. The program calculates the mean and standard deviation for each interval and statistical comparisons of adjacent intervals by the method of Student's t and Mann-Whitney tests. All input data are stored in a file for further processing in the statistical programs.

Results

A large series of studies and field trials in Russia, Venezuela, Colombia, England, in the period 2008-2014 showed that the instrument is sensitive to changes in environmental parameters²⁶. For example, in August 1, 2008, a series of measurements in Novosibirsk, Berdsk, Irkutsk and Abakan using 7 independent GDV devices during a total solar eclipse was conducted. All experimental curves had two distinct phases: before and after the eclipse (Figure 4). Before the eclipse in all graphs long-wave oscillations of two types were observed: decreasing (for two devices) and increasing (for five devices). After the eclipse signal has stabilized with the variability of less than 1%.

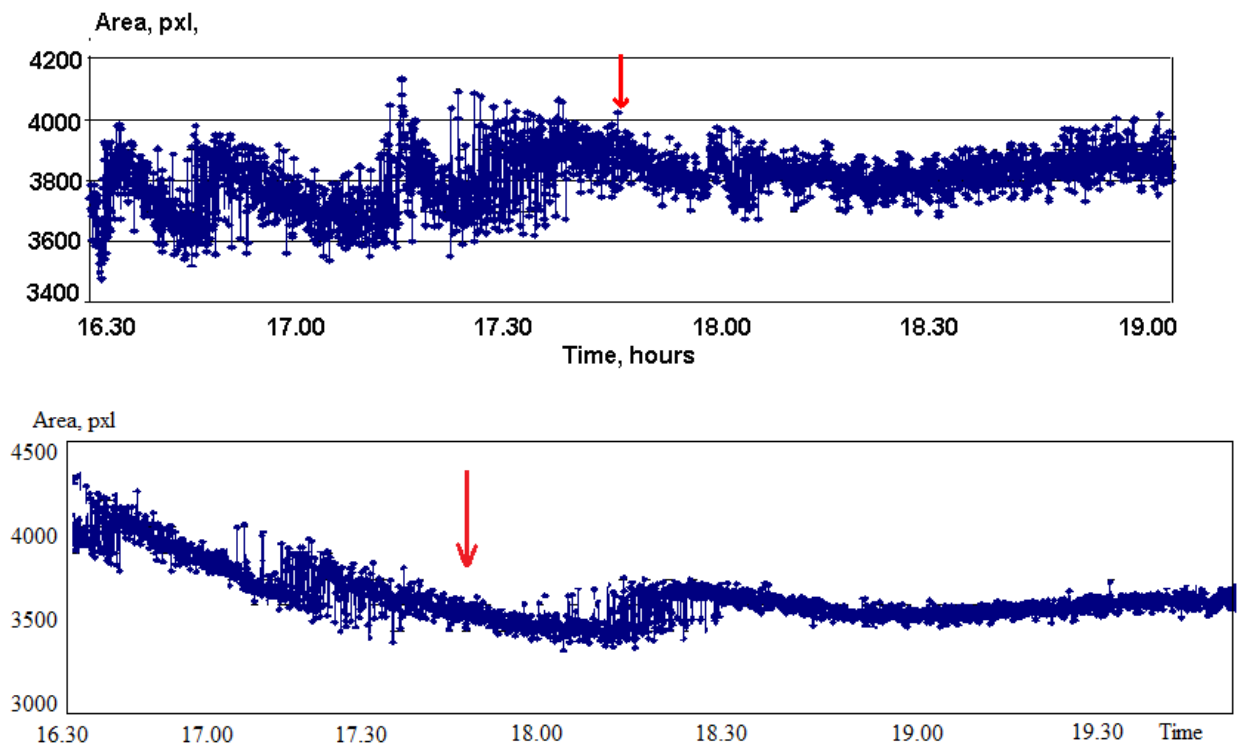

Figure 4. Temporal dynamics of changes in the area of the signal of the "GDV Sputnik" during a total solar eclipse in Novosibirsk 01.08.2008 at two measurement points. The arrow shows the moment of complete coverage of the disk of the sun by the moon shadow.

Measurements have shown that the device responds to the phases of the moon, sunrise and sunset in the southern countries, where this process has a distinct character; variability of the signal increases significantly in geoactive areas²⁷. Vadim Seyidov in Berlin conducted measurements with the "Sputnik" at the same time of the day during the year. He found that the amplitude of the signal varies significantly during the full moon phase²⁸. Of particular interest is the measurement of subliminal psycho-emotional reactions of groups of people.

Based on these data we can conclude that the developed system and methodology allow us to study the change of mental and emotional states of groups of people. Psycho-emotional state closely associated with the functional activity of the human body, such as the nervous system, the endocrine system, the cardiovascular system. In 2009-2015, various researchers in Russia, USA, India, Italy and the Netherlands have held more than 100 measurements during social events, and in all cases reaction to the change of mental and emotional state of the members of the study group was recorded. Studies have shown that the higher the standard deviation of the Bio-gram area, the higher functional activity of groups of people in the test room.

As an example, let us discuss results of a series of measurements in the United States during a workshop conducted by Joe Dispensa 11-14 July 2013. The workshop was attended by 113 people who listened to lectures and had a collective meditation for 80-90 minutes twice a day. Joe Dispensa guided the process of meditation in the hall with calm music. Bio-Well device with "Sputnik" sensor and the computer were installed in the corner of the room, the recording was carried out automatically with the processing of data on the server in real time every day before and during meditation in the morning and afternoon session for 6-8 hours continuously.

The day before the seminar recording of a sensor signal for 4 hours in an empty workshop room was conducted. After establishing a stable signal level 20 minutes after the start of measurement variability signal does not exceed 10-15%. Analysis of the data showed a decrease in the signal of the sensor in the process of meditation (Figure 5). Signal processing data were broken up into 10 minute intervals, allowing calculates the average values and standard deviations.

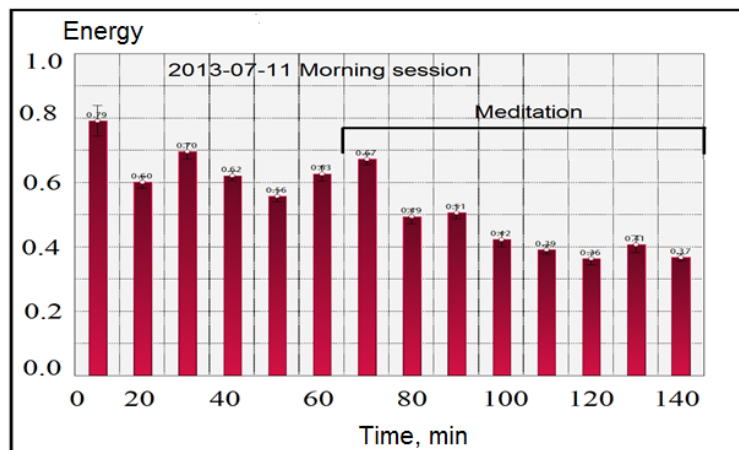

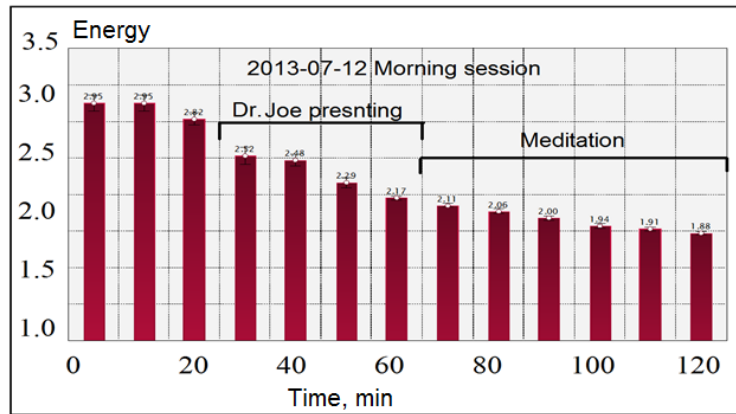

Fig. 5. An example of a signal processing recorded during a morning session on 11 and 12 July 2013.

Decrease in the signal in the process of meditation for all 4 days of the workshop was observed. During the break, the signal level increased. There was also an increase in the signal from day to day (Figure 6).

Similar measurements were carried out repeatedly at various seminars. Interesting trends in the measurements during musical performances were found. Numerous experiments have shown that in most cases the output signal of the device changes significantly at the "live" musical performances.

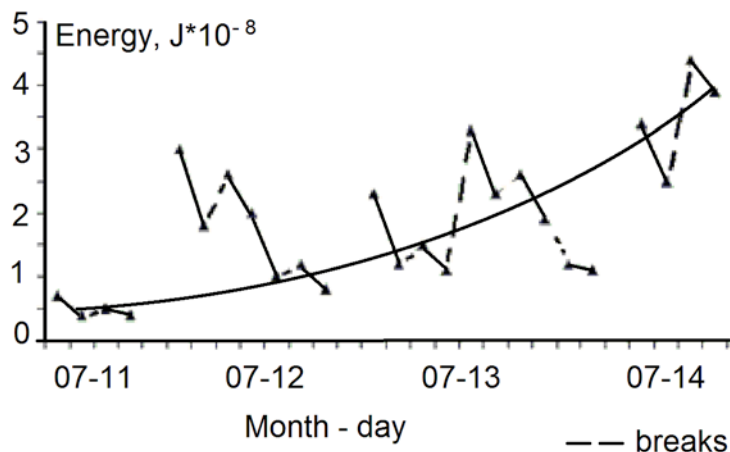

Figure 6. The mean values of the signal energy at the beginning and end of each session during the 4 days of Joe Dispensa seminar.

Conclusion

The use of Bio-Well in conjunction with a special "Sputnik" antenna allows monitoring both non-selective characteristics of the environment and the functional state (in particular emotional state) of groups of people. The developed method was tested during theater performances and concerts, workshops and lectures, as well as in the process of group meditation. In many cases correlation of Bio-Well parameters and emotional state of the audience was recorded. A series of devices to work with the sensor is developed and produced. Data processing is carried out on the server in real time (www.bio-well.com). Russian Company avdspb.ru offers services in the comprehensive analysis of environmental parameters as in the

open air and indoors. Sensor can be used in education, security services, geophysics, study of geo-active zones. Currently, different researchers use more than 100 devices with a "Sputnik" sensor.

Correlation measurements are planned to link the signal of the experimental system with changes of physiological parameters such as EEG, ECG, GSR, etc., as well as changes in the level of infrasound, ultrasound, noise pollution, radiation, electromagnetic fields of different range and amplitude.

References

- ¹ Melnikov EK Pivovarov GM, Metkin NP. Geodynamic zones of active faults and their impact on human health. Teaching aid. St. Petersburg. Ed. "Ladoga-100." 2013 76.
- ² Jastrebov VS Geoactive and geopathic zones Earth and dangerous manifestations // Vestn. RANS. - 2005 - Vol.5, N 4. - pp.71-79.
- ³ Melnikov EK Biological zone of discomfort associated with the inhomogeneities and the geological structure of the earth's crust. St. Petersburg Center MANEB 2008.
- ⁴ Kolesnik AG Kolesnik, SA, SV Pobachenko Electromagnetic environment: studies. allowance. - Tomsk: TML-Press, 2009 - 336 p.
- ⁵ Burlakov AB, Kapranov YS, Kufal GE, SV Perminov Anthropogenic disturbance of the ionosphere as a destabilizing factor correlations geliobiosferyh // Vestn. The Kaluga. Univ. - 2007. - N 1. - pp.15-24.
- ⁶ Korotkov KG. Human Energy Field: Study with GDV Bioelectrography. Fair Lawn, NJ: Backbone Publishing Co: 2002.
- ⁷ Hossu M, Rupert R. Quantum Events of Biophoton Emission Associated with Complementary and Alternative Medicine Therapies. J Altern Complement Med. 2006, 12(2): 119-124.
- ⁸ Cohly H, Kostyuk N, Isokpehi R, Rajnarayanan R. Bio-electrographic method for preventive health care. Biomedical Science & Engineering Conference, First Annual ORNL, 2009,1-4.
- ⁹ Rgeusskaja GV, Listopadov UI. Medical Technology of Electrophotonics – GDV – in Evaluation of Cognitive Functions. J Sci Healing Outcome. 2009, 2(5): 16-19.
- ¹⁰ Kostyuk N, Meghanathan N, Isokpehi R.D., Bell T, Rajnarayanan R, Mahecha1 O, Cohly H., Biometric Evaluation of Anxiety in Learning English as a Second Language. International J Computer Science and Network Security, 2010, 10(1): 220-229.
- ¹¹ Aleksandrova E, Zarubina T., Kovelkova M., Strychkov P, Yakovleva E. Gas Discharge Visualization (GDV) Technique is New in Diagnostics for Patient with Arterial Hypertension. Journal of New Medical Technologies, 2010,XVII(1):122-125.
- ¹² Bundzen PV, Korotkov KG, Unestahl LE. Altered States of Consciousness: Review of Experimental Data Obtained with a Multiple Techniques Approach. J Altern Complement Med. 2002, 8(2): 153-165.
- ¹³ Korotkin DA, Korotkov KG, Concentration dependence of gas discharge around drops of inorganic electrolytes. J Applied Physics. May 2001, 89(9): 4732-4736.
- ¹⁴ Korotkov K, Orlov D. Analysis of Stimulated Electrophotonic Glow of Liquids. www.waterjournal.org/volume-2-index. 2010, 2, accessed 12-01-2010.
- ¹⁵ Szadkowska I. , Masajtis J., Gosh J.H. Images of corona discharges in patients with cardiovascular diseases as a preliminary analysis for research of the influence of textiles on images of corona discharges in textiles' users. Autex research journal, 2010, 1. 10: 26-30.
- ¹⁶ Augner Chr., Hacker G.W., Schwarzenbacher S., Pauser G.: Gas Discharge Visualization (GDV): Eine auf physikalischen Methoden und Meridiananalysen basierende Technik zur Untersuchung von Stressreaktionen und energetischen Schwachstellen – Zwischenbericht laufender Forschung. Dt. Ztschr. f. Akup. (DZA) – German J Acupuncture & Related Techniques 2010, 53: 14-20.

- 17 Korotkov K, Orlov D, Madappa K. New Approach for Remote Detection of Human Emotions. *Subtle Energies Energy Med* 2009, 19(3): 1- 15.
- ¹⁸ Korotkov K, Shelkov O, Shevtsov A, Mohov D, Paoletti S, Mirosnichenko D, Labkovskaya E, Robertson L. Stress Reduction with Osteopathy assessed with GDV Electro-Photonic Imaging: Effects of Osteopathy Treatment. *J Altern Complement Med.* 18, 3: 251-257, 2012.
- ¹⁹ Alexandrova R., Fedoseev B., Korotkov K., Philippova N., Zayzev S., Magidov M., Petrovsky I. Analysis of the Bioelectrograms of bronchial asthma patients. In: Proceedings of conference "Measuring the human energy field: State of the science". National Institute of Health. Baltimore, MD, 2003: 70-81.
- ²⁰ Yakovleva E, Korotkov K. *Elektrophotonic applications in medicine. GDV Bioelectrography research.* 2013. 134 p. Amazon.com Publishing.
- 21 Mandel P. *Energy Emission Analysis; New Application of Kirlian Photography for Holistic Medicine.* Synthesis Publishing Co., Germany. 1986.
- 22 *Measuring Energy Fields: State of the Art. GDV Bioelectrography series. Vol. I.* Korotkov K. (Ed.). Backbone Publishing Co. Fair Lawn, USA, 2004.
- 23 Korotkov K.G. *Les Principes De L'Analyse GDV.* Marco Pietteur, Editeur, Belgique, 2009.
- 24 Polushin J, Levshankov A, Shirokov D, Korotkov K. Monitoring Energy Levels during treatment with GDV Technique. *J Sci Healing Outcome.* 2009, 2(5): 5-15.
- ²⁵ Hacker GW, Pawlak E, Pauser G, et.al. *Biomedical evidence of influence of geopathic zones on the human body: scientifically traceable effects and ways of harmonization,* *Forsch Komplementärmed Klass Naturheilkd,* 2005; **12**: 315-27.
- ²⁶ Korotkov K. G. *Energy of Space.* Amazon.com Publishing. 2014.
- ²⁷ Orlov DV, Korotkov KG Measurement of the energy characteristics of the space by the gas discharge visualization. VIII International Crimean Conference "Cosmos and Biosphere": abstract, 2009 pp. 251-253.
- ²⁸ Seidow B. Measurement Sputnik sensor signal during the year. XVII International Scientific Congress "Science. Information. Consciousness ": Proceedings, p. 25 2013.

Living Organisms and Structures in the Physical Vacuum

Nina SOTINA

Ph.D. in Physics

Email: nsotina@gmail.com

Introduction

Even shallow analysis of the behavior of living substance showcases of conundrums met by physicists struggling to describe a living system in terms of previously known laws of nature. Below we will discuss some of these conundrums in details. The main one is due to a high degree of determinism manifested by biomolecules in a living organism. Indeed a biomolecular, from the physics point of view, is a quantum system which behavior should be governed by the probabilistic laws of quantum mechanics. Schrödinger was the one who pointed out that Quantum Mechanics in its present day form is unable to describe a behavior of living matter [1]:

“A single group of atoms existing only in one copy produces orderly events, marvelously tuned in with each other and with the environment according to most subtle laws... we are here obviously faced with events whose regular and lawful unfolding is guided by a ‘mechanism’ entirely different from the ‘probability mechanism’ of physics.”

The question on whether or not the quantum mechanics describe the physical reality adequately arises even for non-living matter. Historically, the issue of incompleteness of quantum mechanics was put forward for the first time by Einstein, Podolsky, and Rosen in 1935. They proposed the existence of “hidden variables” which allow a quantum system to be consistent with the deterministic theory. However, it was proven later on that any theory of “hidden variables” claiming to be able to describe experimental results must be “nonlocal” only. Disregarding action at a distance, “nonlocality” means existence of a physical field which allows for interactions to attain speeds greater than the speed of light. As known the speeds greater than the speed of light contradict the theory of relativity. However, we should admit that at present time there is no physical interpretation of quantum formalism that would not have contradictions within it or with accepted ideas and theories. Such situation in quantum mechanics is an important argument in support of the necessity of essential changes in physics.

In the opinion of the author of the present work the incompleteness of description of a living nature by quantum mechanics is an argument in favor of the deterministic (causal) interpretation of quantum formalisms. It was proven in articles [2, 3] that the Schrödinger equation can be derived from the deterministic laws of classical mechanics, taking into consideration the existence of “hidden variables” like a physical field. Under this approach the Schrödinger equation is a necessary condition of a stable motion of electrons in an atom. Besides that this approach gives us a strong mathematical base with which to suggest that some spatial structures in a physical vacuum accompany an atom. These structures are responsible for stabilization of the electron’s motion in an atom.

The more complicated a quantum object (atom → molecule → biomolecule and etc.) is the more complex is the structure that accompanies it in the physical vacuum. Obviously, the

structures that are accompanying living systems ("biostructures") fundamentally differ from structures which are accompanying non-living quantum systems. As it will be demonstrated below many conundrums could be resolved if we suppose that living systems and pre-life molecular organizations have their "continuations" in the physical vacuum, which are structures composed of elements of non-molecular nature [4]. These structures hold information and energy necessary to control biochemical processes. Such approach is in agreement with the idea of Eugene Macovschi who postulated the existence of the "cellular biostructure" [5, 6].

1. Macovschi' concept of a biostructure.

The size of a hydrogen atom is about 10,000 times greater than the size of its nucleus. What fills the space between the nucleus and the electron? What fills the space between elementary particles or between distant stars?

In the late 19th century the continuous medium that fills the Universe was called luminiferous aether. According to contemporary physics the interaction between particles is the interaction of the quantum fields. In the absence of particles, the corresponding fields are in their lowest energy states (*vacuum states*), and the continuous medium that fills the real three dimensional space, when all known fields are in *vacuum states*, is called the physical vacuum. Modern physics does not answer the question what happens to this medium in the case when one of the fields is not in a *vacuum state*. In this work we will call the medium that fills the Universe the physical vacuum regardless of whether all the fields are in their *vacuum states* or not. Although the nature of the vacuum remains mystery, the Casimir effect, the Lamb-Retherford effect (Lamb shift), the birth of electron-positron pairs in strong electromagnetic field are evidences of a complex microstructure of the physical vacuum.

The idea that a living organism is not just a material substance, that is accumulation of molecules, but also some non-molecular (intangible) structure in the physical vacuum goes back to the mists of time. Romanian biochemist Eugene Macovschi (1906-1985) was the first who made an attempted to approach this idea scientifically. According to Macovschi, living cells consist of two qualitatively different, though interacting, forms of matter: a specific form of structured matter ("biostructure") and coexisting molecular matter, chemicals. He guessed that the biostructure is an entity carrying the control function in living cells, and that this control is irreducible to electric and electromagnetic interactions. Eugene Macovschi re-evaluated the results of some experiments that were explained by their authors on the basis of the molecular theory [5, 6].

The starting point for Macovschi and his coworkers was the following observation: after being exposed to 200 ATMs hydrostatic pressure, the living plant tissues released a certain amount of water and still remained alive. In the case of a dead tissue the situation was quite different: after exposing to 200 ATMs a dead tissue released all the water it contained. Then, Macovschi postulated that life depends on the biostructure integrity and that it can stand rather high hydrostatic pressures without breakdown, i.e. without releasing all the water it comprises. The killing of the residue led to the biostructure breakdown and to the release of the biostructured water it contained.

According to the present molecular concept, water occurs in both living and dead tissues under only two main states: free and bound. Of course, water in the vicinity of the solid surfaces, free ions, macromolecules, and so on of the cell exhibit properties different from ordinary water. Once the biological water is released from the biological system it immediately regains the properties of ordinary water. According to contemporary biochemistry, the living matter and the dead one consist of the same substances and are not qualitatively different. It follows from this experiment, however, that two forms of matter, living and dead, are fundamentally different.

Note that Macovschi's ideas of biological structures stand out from all other explanations of organism behavior. At the same time some scientists tried to explain mysterious phenomena in biology by introducing a new kind of physical field (*the biofield*), which was presented in living organisms only. Note that the term "the biological field" was introduced by A. Gurvitsch at the beginning of the 20th century. He suggested the existence of non-chemical level of organization that controls embryogenesis. According to Gurvitsch the nature of "the biological field" lies within electromagnetic phenomena. However, later on there were papers by other authors that considered biofield, as a new type of field, having non electromagnetic nature. For example, the work by S.Savva "Biofield control system" [7] who considered biofield as a non-electromagnetic control system of the living organism, that carried all fundamental programs of life.

By the term "physical field" Gurvich and his followers understood the classical definition of a field, the agent that transmits action from one object to another. For example, interaction between charged particles is transmitted via electric field. In physics, a field is a quantity that has a value in each point in space that is a field in most case has a property of continuity. A spatial structure, on the other hand, is a system composed of elements (items) of arbitrary nature and has a definite shape (Macovschi viewed the biostructure as a sponge). Here lies a significant difference between structures and the physical field.

It is important to note that in order for non-molecular structures to be stable and at the same time dynamic there are must exist some kind of interaction which controls the coherent behavior of the distant elements of the structure. Therefore, in the case of the biostructure there must be **interaction among non-molecular elements of the structure** which in turn controls the behavior of biomolecules. Thus, to understand biostructures it is important to go beyond the molecular level in the investigations, into finer level of matter.

Let us give two examples of the simplest non-living structures.

The first example. A vortex in a liquid. The vortex is a structure in a liquid, which elements are the liquid particles, and the coherent behavior of distant particles in this structure is controlled by the pressure.

{Note, that the pressure in an ideal incompressible fluid is transmitted simultaneously over entire volume, that is, there is an instantaneous connection between distant particles. However, no one talks about nonlocality or about information potential in hydrodynamics. Nonlocality here, is merely a part of the model. In real fluids there exists a pressure wave, a "precursor", which propagates with speeds much greater than that of the moving body.}

The second example. Consider a liquid with iron filings in it. A submerged magnet in the liquid would make the filings to form a certain structure. The elements of the structure in this case are the iron filings and the coherent behavior of distant elements is controlled by magnetic field.

Despite the Macovschi' concept of a biostructure and a number of conundrums encountered by biophysicists, modern biology continues to develop solely within boundaries of molecular concept which does not provide a satisfactory understanding of the specifics of a living matter. The main reason for that is the theory of relativity which prevents the further development of the concept of biostructure. Indeed, if spatial structures existed in physical vacuum then it would be possible to link a coordinate system with them, and it would be possible to introduce an "absolute motion" of objects with respect to vacuum, which contradicts the first postulate of special relativity – the postulate of relativity.

2. "Intelligent" behavior of the bacteriophage from the physics standpoint.

For explanation of the behavior of the living and pre-life organizations the modern physics has only four types of fundamental interactions: 1)strong nuclear, acting in range of 10^{-13} cm. 2)electromagnetic, with the infinite range, 3)weak nuclear, acting in range of 10^{-16} cm. 4)gravitational, with an infinite range. (Note that both strong and weak nuclear forces are "shorthanded" and gravitational forces are weak). Below we will show, taking the behavior of a bacteriophage as an example, that the explanations of the behavior of the living organisms proposed by biologists only on the basis of the known interactions in physics are unconvincing.

Viruses are microscopic particles that can infect the cells of a biological organism. Viruses that infect bacteria are known as bacteriophages. The bacteriophage T2 is one of them. The phage is hundred times smaller in size than the microbe cell and looks like a tadpole. A "head" (a protective protein shell) contains DNA (some types of bacteriophages contain RNA only). A "tail" is a protein tube. By six legs, the phage attaches to the surface of the much larger bacterium. Once attached, the bacteriophage injects DNA into the bacterium. The DNA instructs the bacterium to produce masses of new viruses.

Note, that viruses are generally not considered to be true living organisms because they do not use any external energy (food, radiation), and cannot reproduce without getting inside some living cell.

The following is an approximate list of the bacteriophage's functions.

- a) Detecting (done at a range of several phage's own lengths) and turning the tail towards the bacterium.
- b) Attaching to the surface of the bacteria and penetrating it with the tail.
- c) Injecting genetic material into the bacterium. (The contraction of phage's "head", the simultaneous cooperative shift of its protein subunits with respect to each other occur, which makes the tail become shorter and thicker).

From the physics standpoint, the "intelligent" behavior of the dumb bacteriophage must be caused by some physical phenomenon of interaction. Thus some researchers suggest that:

- a) detecting and turning towards the bacterium is done by electrostatic forces. {However this is not very convincing because the abilities of electrostatic forces are limited (there are only two signs of a charge + and -), at the same time the variety of phages in the micro world is

enormous and every phage parasites on its own type of bacteria}.

b) attaching to the surface of a bacterium occurs due to Van der Waals forces. These forces appear as a result of a change in the configuration of electrons and nuclei.

c) injecting of genetic material, partially occur due to the pressure difference (DNA is packed tightly inside the protein shell of a phage; as a result of that DNA has elastic energy and exerts pressure on the walls of the protein shell). Interaction of DNA and protein, that is explained to be due to the formation of the special correlations of electric charges, also plays an important role in the process.

However the above reasoning alone cannot explain the tremendous stability of the molecular machine, as well as the coherence and a high degree of determinism of biomolecules behavior. Thus, if assume that the interactions between biomolecules is due to the complex special correlations alone, then how to explain the stability observed in the functioning of a bacteriophage at the temperature around 300K? The heat fluctuations should have caused disorder in the complex mechanism. It is reasonable to suggest that any living system and pre-life molecular organization have their “continuations” in the physical vacuum, which are structures composed of elements of non-molecular nature. These biostructures hold information and energy necessary to maintain stability of complex organic molecules and to control biochemical processes.

3. Problems of self-organization in animate matter

One of problems met by physicists struggling to describe a living system in terms of the laws of inanimate matter is violation of the previously know laws of self-organization in living systems.

According to the second law of thermodynamics, an isolated system (that can exchange neither energy nor matter with the outside) slowly evolves from an ordered initial state with low entropy to a disordered equilibrium state corresponding to higher entropy (order means the localization of particles or energy in some space region). The discovery of this law in the 19th century dispirited many people because it meant that our Universe moved inevitably to a completely disordered state (chaos), or its “heat death”. Fortunately, however, the reverse process, the self-organization of highly ordered structures from simpler ones or even from chaos, can also be observed in nature. There is no violation of the second law because, thermodynamically, self-organization takes place only in open (non-isolated) systems.

The term “self-organization” appeared for the first time in the scientific language in the beginning of the 1970s as a collective term for numerous natural phenomena. Self-organization, as implied by its name, occurs without directed influence from outside. If the external energy or mass influxes do not allow the system to evolve to the equilibrium, the structures formed spontaneously may be fairly stable. System is able to transit spontaneously from chaotic state into an ordered state. Thus self-organization in physical and chemical processes originates, as a rule, in open non-linear systems. When observing self-organization, a quantitative measure, called the correlation distance, can be introduced to determine the interaction between distant elements of the structure.

A typical example of regular structures formed spontaneously from a chaos is the so-called Bénard cells that formed as the result of convection in fluids. In the convection developed due

to the heating of a fluid from below, one can observe the onset of dissipative structures, the Bénard cells. If the external energy or mass influxes do not allow the system to reach equilibrium, these structures may be fairly stable.

Complex organisms are also an example of self-organizing structures developing from embryos. In the process of growth, the organism “consumes” energy and matter supplied from outside, owing to which it is not only conserved but is developed into a higher level of organization. Thus, the organism is like a self-organizing structure of inanimate matter that develops in an open system. However, this is the only similarity between the structures. The development of an organism follows strictly determined laws remaining valid through generations and is unlike the spontaneous development of structures of the inanimate matter. Schrödinger was possibly the first who drew attention to that. He wrote [9]:

“The living organism seems to be a macroscopic system which in part of its behaviour approaches to that purely mechanical (as contrasted with thermodynamical) conduct to which all systems tend, as the temperature approaches the absolute zero and the molecular disorder is removed.”

E. Schrödinger specified two principles of the ordering process in the inanimate and animate nature.

1. Creation of “**order from disorder**”. This way of ordering is observed in an open system if the system is **in a strongly non-equilibratory state**.

2. Creation of “**order from order**”. This refers to ordering which is constantly supported.

Life selected the latter principle. The development of an organism follows certain strictly defined laws **under quasi-equilibratory** (from the point of view of thermodynamics) **external conditions**.

Let us point your attention to another interesting feature of the process of ordering in the animate nature: self-organizing structures can develop without the external energy or mass influxes, and sometimes on the contrary - part of the molecules are released and transferred to the cell in the process. This can be observed in the process of meiosis (reductive division).

We shall consider in a sketchy way the behavior of the chromosome in meiosis (reductive division) occurring under quasi-equilibratory external conditions. In meiosis the double chromosome set of the parent cell simply separates into two single sets, one of which goes to each of the daughter cells, the gametes. However, before being separated, any two “homologous” chromosomes come into closer contact with each other, during which they sometimes exchange their genes. The process is called “crossing-over”. There is a noteworthy feature of the process: in crossing-over neither energy nor matter are consumed from outside, but, on the contrary, part of the molecules are released and transferred to the cell.

In our view, to come closer to the understanding of the laws of the self-organization in the animate nature it is necessary to go beyond the molecular level in the investigations, to take into consideration the processes in the non-molecular biostructures and the properties of the physical vacuum. It is like an observer of floating filings in the water, who does not see the water, but wishes to describe the motion of filings. The observer clearly feels the lack of

information. She has two choices either to realize that water is present, or to introduce a new term, *information*, in the equations of motion of the fillings.

4. Biomolecules and Quantum mechanics

The behavior of living matter does not obey the laws of another theory - quantum mechanics. Indeed, a peculiarity of the living substance chemistry is that in a living organism, as opposite to a regular chemical environment, molecules mostly interact under control of enzymes rather than via random collisions. An enzyme is a complex protein particularly folded in 3 dimensions. Any enzyme includes a segment (called an active center) where the chemical reaction controlled by these enzymes occurs. An active center can only accommodate predetermined molecules of a particular shape. This process does not exhibit any molecular chaos! On the contrary, the biomolecules act as the well-tuned mechanisms. From the physics point of view, molecule is a quantum system. Quantum system behavior should be governed by the probabilistic laws of quantum mechanics. That is why quantum mechanics is never used to describe biomolecule behavior alone without bringing in heuristic models of enzymatic reactions and concepts of chemical bonds. This obscures the fact that if quantum mechanics is solely used that would lead us to quantum chaos. Let us try to substantiate this claim using indirect argument.

One of an attribute of the chemistry of living things is that the molecular systems in the living substance are in the state of continuous irreversible interaction. However, the energy of a molecule in an unstable case will not have any precise value due to the Heisenberg Uncertainty Principle. Therefore, it is possible to tell only with a certain probability whether a chemical reaction or change of a molecule configuration is to occur. Since chemical reactions in a living substance occur almost continuously, the probability of repetition of the same processes according to quantum mechanics would have to be infinitely small. While in real life we observe surprising stability of development of living organisms: the same processes repeat many times over from generation to generation (and this is a manifestation of determinism: two similar molecular systems evolve the same way).

5. The Schrödinger equation and structures in the physical vacuum

The incompleteness of the description of a living nature by quantum mechanics in a serious reason to move away from the probabilistic interpretation and to turn to another interpretation of quantum formalisms, the causal interpretation. The causal interpretation assumes the existence of "hidden variables". It followed from the violation of Bell's inequalities in quantum theory that any theory of "hidden variables" must be "nonlocal" only. "Nonlocality" means two possibilities: either existence of a physical field which allows for interactions to attain speeds greater than the speed of light, or propagation of "signals" of the changes of a particle's quantum state with an infinite speed.

D. Bohm was the first who introduced "nonlocality" in quantum mechanics. By the term "nonlocality" Bohm understood propagation of "signals" with an infinite speed [8]. It is shown in [2, 3] that some of the Bohm's assumptions were incorrect.

Originally Schrödinger was inspired by the de Broglie's idea of "matter waves". He thought the "matter waves" to be real and envisioned a particle as an actual wave packet. In essence, Schrödinger was, as de Broglie, a supporter of the causal interpretation of quantum

phenomena. That is the reason why to explain the quantization procedure Schrödinger turned to classical mechanics, particularly to the Hamilton-Jacobi equation [9]. As the result of that study Schrödinger obtained his famous equation that described correctly the quantum levels of energy of hydrogen atom. However the derivation of the equation, presented by Schrödinger, for several reasons seemed unclear and even erroneous to physicists. Therefore, the Schrödinger equation was taken as a postulate. In the same year, 1926, M. Born proposed the probabilistic interpretation of wave function.

The author of the present work is a supporter of the concept of «hidden variables» like the physical field, and using this approach derived the Schrödinger Equation from the laws of classical mechanics, using the method utilized by Schrödinger in his work [9], but correcting mistakes that he made [2, 3]. Under this approach, Schrödinger equation was proved to be a necessary condition for stability of a motion of electrons in an atom. Besides that the classical approach provided a strong mathematical base with which to suggest that some spatial structures in a physical vacuum accompany an atom. These structures are responsible for stabilization of the electron's motion in an atom.

Obviously, the more complicated a quantum object (atom → molecule → biomolecule, etc.) is the more complex is the structure that accomponing it in the physical vacuum. The existence of such structures in non-living matter is the crucial argument in favor of the existence of a similar, more complex biostructures, in a living matter.

Acknowledgments.

I would like to thank Nadia Lvov for her help in preparation of the article and for valuable comments.

References

1. E.Schrödinger, *What is Life?*, Cambridge (1944).
2. N. Sotina, "Derivation of Schrödinger Equation from the Laws of Classical Mechanics, Structures in Physical Vacuum", *Physics Essays*, vol.27, p. 321-326 (2014).
3. N. Sotina, "The 'hidden variables' in quantum mechanics. The precession of the electron's spin in an atom", *Proceedings of Natural Philosophy Alliance*, vol.11, pp 113-122 (2015)
4. N. Sotina: "Structures in the physical vacuum", *LIVE and MIND, insearch of the physical basis*", Trafford publishing, Canada, Editor S.Savva, pp. 211-237 (2006).
5. E.Macovschi , *Rev. Roum. Biochim.*, 19, 177-186.(1982)
6. G. Drochioiu, "Eugene Macovschi's concept of biosructure and its current development", *LIVE and MIND, insearch of the physical basis*, Trafford publishing, Canada, Editor S.Savva, pp. 43-60 (2006).
7. S.Savva: "Biofield control system of the organism", *LIVE and MIND, insearch of the physical basis*", Trafford publishing, Canada, Editor S.Savva, pp. 3-24 (2006).
8. D.Bohm , *Phys. Rev.*, 85 (2), 166 (1952).
9. E.Schrödinger, "Quantization as an Eigenvalue Problem", *Annalen der Physik*, 79,361(1926).

Why the Last Century's Quantum Mechanics (QM) is Irrelevant in a Duplex, Reciprocal Subspace, Reference Frame for Our Cognitive World

White Paper # XXXIX

by William A Tiller, Ph.D. and Walter E. Dibble, Jr., Ph.D.

Introduction

Nature is always richer in untapped possibilities than we think it is. We must always keep planting the new “seed corn” of fundamental research so that we might reveal new levels of nature’s expression, which might look like new levels of “magic” as interpreted by the old paradigm. This is because the structural foundations of the old paradigm are **incapable** of explaining the new data. However, all of this **new** data can appear lawful and understandable via a **new** conceptual framework for a **new** paradigm. This, in turn, lays the foundation for abundant new applications that utilize this new knowledge. This provides new opportunities to test ourselves, to become **more** than we were and to show others how they can do likewise.

It is time to help the **quantum mechanical (QM) paradigm** to expand significantly beyond what it presently is! As presently formulated mathematically, quantum mechanics is a very precise theory whose reference frame (RF) of mathematics is a four-dimensional spacetime-only RF within the classical electric particle velocity limits from zero to the velocity of electromagnetic (EM) light, c , in physical vacuum, and involving the four fundamental forces discovered by establishment science to date of (1) gravity (2) Maxwellian electromagnetism (3) the long-range nuclear force and (4) the short-range nuclear force. This theory has been remarkably successful for particle physics, small atoms, molecules and photons. However, many of the outcomes from today’s experiments are requiring weirder and weirder explanations. This is a clear sign that the present conceptual framework of quantum mechanics has reached the limits of its useful modeling capabilities.

Julian Schwinger,⁽¹⁾ along with Feinman and Tomanaga, shared the Nobel Prize for their discovery and mathematical development of quantum electrodynamics (QED). Schwinger had a Ph.D. student Paul Werbos, who made the very prophetic points⁽²⁾ that (1) all forms of quantum electrodynamics : Copenhagen, Bohmian, Schwinger-type or Werbos-type yield the same kind of predictions and **none of them** can explain something like “remote viewing” (I assert that his statement applies to **any psychoenergetic phenomenon**), and (2) he tells us that the world has spent billions of dollars to use

quantum electrodynamics in the military to see things very far away and it has completely failed to do so. The point, here, is that our present formulation of quantum mechanics, great as it is, is totally inadequate to encompass the inclusion of psychoenergetic phenomena into our scientific worldview. Thus, it is time to formulate a **larger** perspective or scientific reference frame for viewing nature that **both** accounts for all of the old data and also provides the possibility of quantitatively accounting for this new psychoenergetic data in an internally self-consistent way.

Harrison⁽³⁾ has shown that **all** the applications of the last century's QM can be properly calculated provided that one assumes **the simultaneous existence in nature of both a particle and a wave expression for any physical substance!**

A serious scientific problem, as this author sees it, is that, **cognitively**, none of us has ever seen continuous waves like those drawn in science textbooks. The actual waves that most humans see or hear in today's world are all **modulations of particle** densities or modulations of **particle** fluxes. In any event, it is the oscillatory, time-dependent, bunching of particles to create the **envelope shapes** that we name as waves cognitively.

Because of this, the founding fathers of QM **should have** taken the **large step** of creating and using a **different reference frame** for the **waves** than for the **particles**, however, they did not, they tried to squeeze it all into a spacetime-only reference frame (RF) and thus ended up in perpetual weirdness for QM physics!

Via this author's^(4,5) and his colleague's⁽⁴⁾ intellectual creation of a duplex RF consisting of two, reciprocal, four-dimensional subspaces, one of which is spacetime, plus a coupler substance⁽⁶⁾, allows a substance's particle-nature to function in spacetime (D-space), its wave-nature to function in Reciprocal space (R-space) and what has been labeled "deltrons" to function as the coupler substance. Thus, in this particular RF, particles **and** waves **simultaneously** function in an expanded physical reality!

What this actually means is that, since D-space is treated as the coarse electric, physical space, (where both, most of the space **between** the fundamental particles making up the coarse electric atoms and molecules and what we call "outer-space" (where a negligible electric atom/molecule density exists)), can be considered as a **non-dispersive** physical vacuum medium for electric substance (current experimental data shows that coarse EM-waves of all frequencies travel through physical vacuum **without** diminution of velocity due to interactive scattering). Thus, the very simple relationship of $v = \lambda f$ (v = velocity, λ = wavelength and f = frequency) holds for all electromagnetic waves and therefore Eisberg's simple analysis⁽⁷⁾ also holds. This unequivocally leads to the result given in Figure 1a that shows:

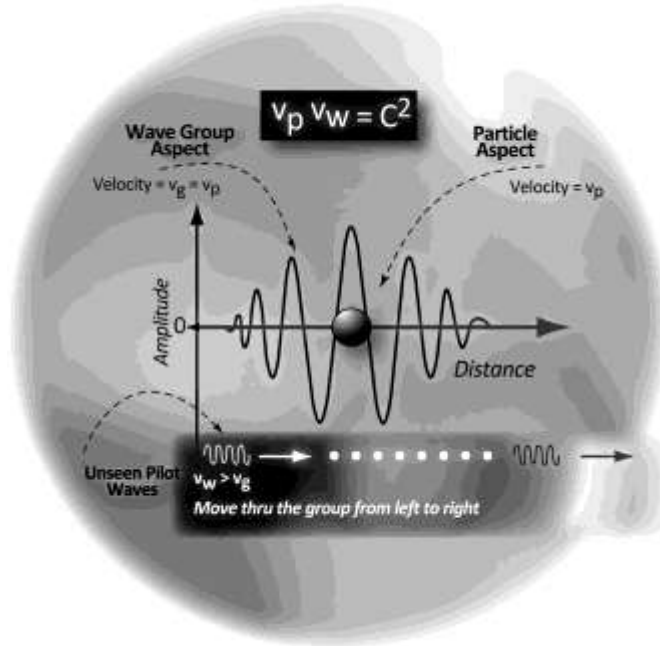

Figure 1a. Schematic of true pilot waves.

1. The electric particle velocity, v_p , equals the group wave velocity, v_g , illustrated in Figure 1b

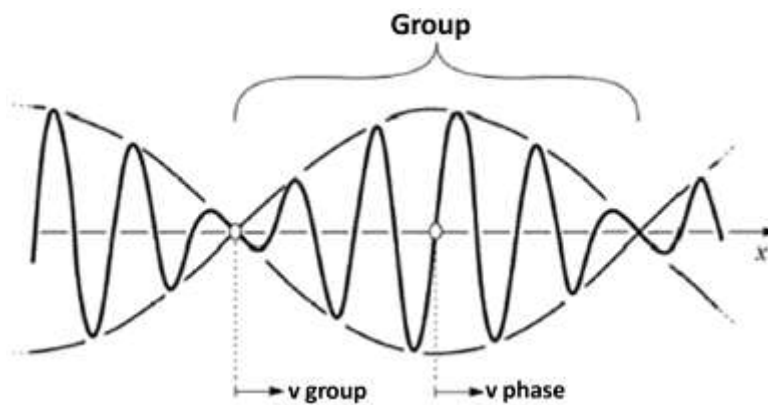

Figure 1b.

Example of a group of waves moving along the x-direction. The entire group of wavelets propagates with group velocity v_{group} . Individual wavelets propagate with phase velocity v_{phase} .

2. Both of these travel at v less than the velocity of light in physical vacuum, $v = c$, and

- DeBroglie's pilot wave, v_w , is calculated to travel at velocities faster than v_p less than c which means that v_w is superluminal and thus both invisible to most human's eyesight and to all of our orthodox science instruments from a D-space mathematical perspective. This means that any R-space substance and R-space natural phenomena in today's world must be treated as mathematically imaginary.

Thus, from this interactive duplex space perspective, at least at this point in time, any single point in that space has a mathematically dual character which, in a two-dimensional Euclidian Geometry, for a D-space-only RF looks like Figure 2. The algebra needed for working with this kind of system is the algebra of complex variables⁽⁸⁾. As one might guess, expanding this Argand diagram concept of Figure 2 to this particular duplex space concept leads to a new way of looking at our world. Using the D-space-only Argand diagram example, the standard complex variable approach, is to define a complex number, z , as

$$= x + iy \text{ or } z = x + yi ; i = \sqrt{-1} \quad (1a)$$

where i is called the imaginary unit.

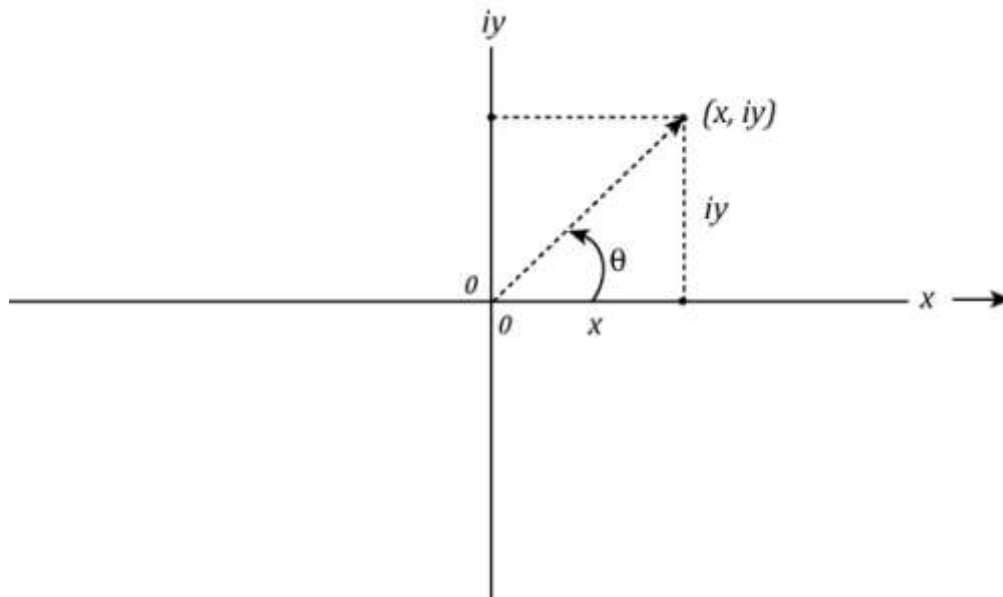

Figure 2. Illustration of a point at position, (x, iy) , in a two-dimensional Euclidian, mathematically complex space with real abscissa and imaginary ordinate (a complex number z can be defined as $z = x + iy$ or $x + yi$ – this is called an Argand diagram)⁽⁸⁾.

At this point, the important thing for us to recognize here is that the point, $z = x + iy$, can be treated as a vector with amplitude, $|x + iy|$, and phase angle, θ , relative to the x -axis. Because the symbol, $| \quad |$, means the absolute value, the amplitude of the vector is always positive. Likewise a line connecting any two points in an Argand diagram is also a vector. If x and y in Figure 2 are real, the nonnegative real

number, $\sqrt{x^2 + y^2}$, is called the **absolute value** or **modulus** of the complex number z . thus, by definition,

$$|z| = |x + iy| = \sqrt{x^2 + y^2} \quad . \quad (1b)$$

Further, any quality, like a particular substance property or energy can be represented by a point in the Argand diagram with the vector magnitude being totally defined by

$$z = |z| \exp(i\theta) = |z|(\cos\theta + i\sin\theta). \quad (1c)$$

Thus, as θ increases from 0° to 360° the exponential term, $e^{i\theta}$, moves from the first quadrant, (positive valued, so z is positive) to the second and third quadrants (negative valued so z is negative) to the fourth quadrant (again positive valued so z is positive). In this type of formal mathematical Argand diagram representation, we can begin to understand what Dirac's "**negative energy sea**" means for the source of electric matter and antimatter particles in our D-space world⁽⁹⁾. Here, in our simplest, one-dimensional, duplex, reciprocal subspaces world of a subluminal D-space and a superluminal R-space with coupler (from a D-space cognitive perception), we can explain many phenomena that have been misunderstood in the past. Let us look at some examples, to illustrate the concepts involved via the Argand diagram metaphor.

A. The Placebo Effect⁽¹⁰⁾

This example has been meaningfully discussed in Reference 10 so that only a brief summary will be given here.

Our experimental work of the 1997-2000 period⁽⁴⁾ showed, unequivocally, that human consciousness, in the form of specific human intentions, can robustly alter the properties of materials as illustrated in Figure 3.

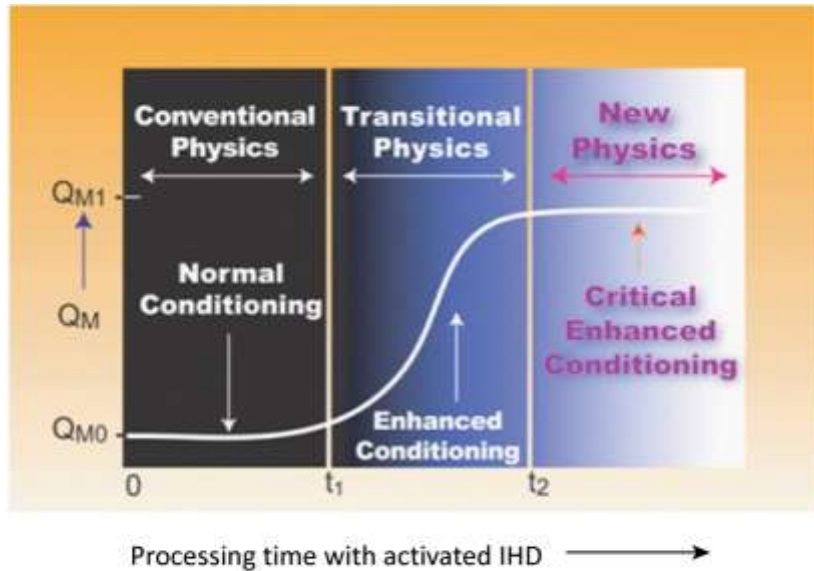

Figure 3. For any typical physical measurement, Q , the qualitative magnitude change, Q_M , is plotted versus the degree of locale conditioning produced by continued IHD use.

Let us call, Q , the material property to be explored and, $Q_M(t)$, the experimentally measured magnitude of that particular property as a function of time, t , during the experiment. In a zeroth-order mathematical approximation, we found that

$$Q_M(t) = Q_e + \alpha_{eff}(t)Q_m. \quad (2)$$

Here, Q_e is our normal D-space contribution, Q_m is its R-space counterpart (superluminal) and α_{eff} is the coupling coefficient joining these two contributions in our duplex subspaces world. Thus, our current working hypothesis is that what we call **physical reality** consists of two unique categories of substance (subluminal and superluminal) in the same physical space. However, only one, Q_e , is accessible to our present-day orthodox (subluminal) measurement instruments when α_{eff} is zero.

The R-space level of physical reality (superluminal) is **invisible** to traditional physical, chemical, medical instruments when the system is in the **uncoupled state** ($\alpha_{eff} = 0$), but is accessible to these same instruments when the system is in the coupled state ($\alpha_{eff} > 0$). This second level (R-space) is the level of reality being largely manifested via human psychophysiology and is the experimental domain being pursued by CAM (complementary & alternative medicine).

These two, unique levels of reality can be partially coupled via (a) a simple electrical intention-host device (IHD) that (i) increases the magnitude of α_{eff} and (ii) directs it towards a specific purpose or (b) a significant biofield subtle energy emission from a human.

One of this author's working hypotheses is that Figure 4 provides a simple picture of the five key factors involved in any vector-system's interactive relationship. In this regard, it is useful for us to have a mental

picture as to how we operate in life with respect to one another. Usually, all five components of Figure 4 may be intimately involved in the system's interactions. Now, let us look at the classical medical experiment with a placebo such as illustrated in Figure 4 (neglecting the "unseen" and higher Gauge symmetry states as in Figure 5).

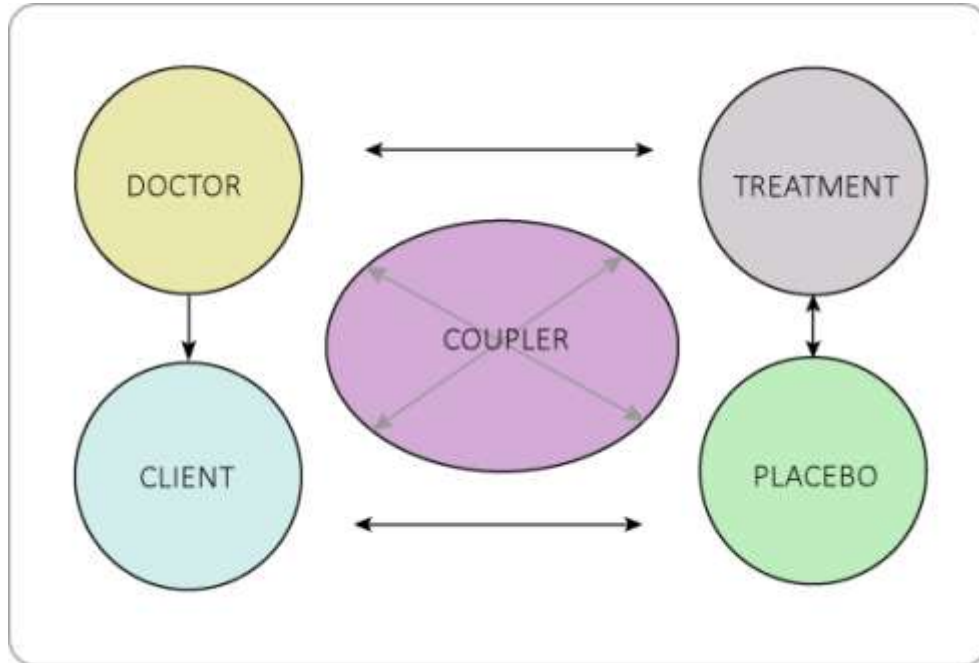

Figure 4. Illustration of a typical medical vector-system experiment.

My interest in this phenomenon of Nature began on reading a short 1999 paper by Enserink⁽¹¹⁾ who noted how greatly the placebo effect's magnitude in double-blind pharmacological studies had grown in the previous 15 years. He pointed out that, "when companies started testing drugs for obsessive – compulsive disorder (OCD) back in the mid-1980's, the placebo response rate in this old testing was almost zero". Thus, the normal experimental assumption that the placebo in the experimental protocol was an inert participant was a good approximation to the truth at that time.

However, as time passed, the placebo response rates began to creep upwards to a point in 1999 where they were 70% to 80% of the treatment response rates and one could reasonably conclude that some clinical trials failed because of high placebo response rates. How is this possible if the placebo behaves in the overall experiment as an inert object? Let us look into that, because according to Equation 2, if something is happening in Nature to cause α_{eff} to slowly increase with time, but in an accelerating fashion, then the connectivity between things would likewise increase in an accelerating fashion and the second term on the right of Equation 2 could be of negligible size in the mid-1980's and of a significant portion of Q_M in 2000.

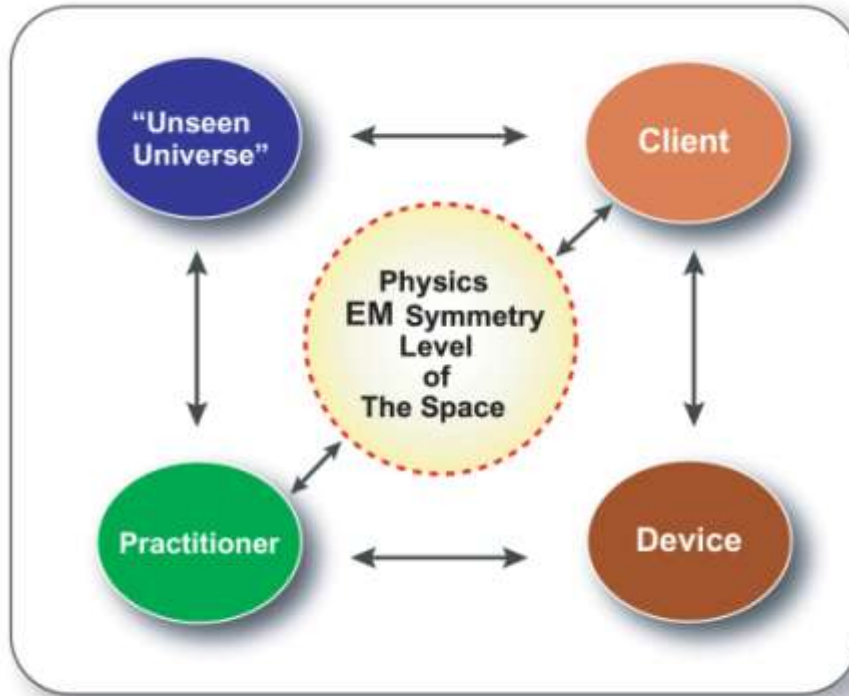

Figure 5. The simplest possible general communication system between practitioner and client in CAM.

In Appendix I, the magnetic information wave aspect of the system represented by Figure 5 has been worked out and one can readily see that a macroscopic information entanglement between all of the designated subsystems of the overall system can occur and further, that this piece of physics is the origin of the placebo effect. The relevant aspects of physics are the following:

- (1) In R-space, each subsystem must be represented as a vector with both amplitude, $R(\underline{k})$, and phase angle, $\theta(\underline{k})$, where each is a function of the position coordinate, \underline{k} , in R-space,
- (2) The entire system's vector, $R_S(\underline{k})\exp[i\theta_S(\underline{k})]$, is given by the vector sum (head to tail addition) of all the subsystem vectors converted first to common units, where $\exp =$ the exponential function and $i =$ the imaginary number $(-1)^{1/2}$ (or $i^2 = -1$).
- (3) Experimentally, one measures the system intensity I_S which is given by R_S^2 and which involves $R_S \exp(-i\theta_S)$, multiplied by its complex conjugate, $R_S^* \exp(+i\theta_S)$, which eliminates the 'imaginary' part to give a mathematically 'real' quantity.
- (4) I_S is given by two groups of terms, (a) the sum of the squares of each vector amplitude and (b) the sum of pairs of different vector amplitudes multiplied by the cosine of the phase angle differences between these pairs and
- (5) the total information entanglement for the Figure 5 system is given from 4b above.

Now, let us consider a typical clinical trial involving the subsystems (i) doctors, D, (ii) treatment, T, (iii) placebo, P, and (iv) subjects, S. For such a system event written in the Equation 1 format using the suffices of these subsystems, the placebo-effect magnitude will be given from Appendix 1 by

$$Q_{MP} = Q_{eP} + \alpha_{eff} \int_k \left[R_P^2 + 2 \left\{ \begin{array}{l} R_P R_D \cos(\theta_P - \theta_D) + \\ R_P R_T \cos(\theta_P - \theta_T) + \\ R_P \bar{R}_S \cos(\theta_P - \bar{\theta}_S) \end{array} \right\} \right] dk . \quad (3)$$

B. The Electrodermal Voll Dermatrom Diagnostic Device⁽¹⁰⁾

The relevant figure here is Figure 5, where the device (a Voll Dermatrom or equivalent) acts much like the **placebo** in the Example A experiment. Reference 10 provides a description and discussion of the electrodermal measurement process while the Voll Dermatrom was a popular commercial device for such a diagnostic investigation instrument for testing the state of a human's health in the 1970-1980s. With such a system, a sensitive practitioner was able to make remarkably sensitive predictions of the particular human's health state and also predictions of viable remedies that "seem to produce and sustain a condition of excellent health for that human!"

However, the FDA could not understand how such a device could possibly produce **any** efficacious results. Taking the device **out of the system** and measuring its properties, they found it to be very predictable to standard electrical engineering behavior. Thus, the FDA **convinced** themselves that there could be no possibility of its beneficial use to the practitioner except **as a fraud**. They raided such practitioners, confiscated all such devices and shut such practitioners down – wrongly (based upon our present understanding of a system of vectors as the proper mathematical perspective in today's world,

$$Q_{MD} = Q_{eD} + \alpha_{eff} \int_k \left[R_D^2 + 2 \left\{ \begin{array}{l} R_{DP} \cos(\theta_D - \theta_P) + \\ R_{DC} \cos(\theta_D - \theta_C) + \\ R_{DU} \cos(\theta_D - \theta_U) \end{array} \right\} \right] dk . \quad (4)$$

C. A Preferred Alternate Explanation for Young's Double-Slit Experimental Result

In today's world, the classical Young's Double Slit experiment:

A. Can be carried out with single photons, one at a time, projected towards a screen but with an intermediate device placed in its path. This device has the capability of opening either one or two parallel and vertically oriented slits, separated by a constant distance, through which the photon may

pass on its travel to the screen. The operator has the ability to open either (1) the left slit only, (2) the right slit only or (3) both slits. The experimental observations for these three options are as follows:

- (a) For only a single slit open, either left or right, the screen shows a single band of light behind the **open** slit (that has grown in intensity as the number of photons increases).
- (b) For both slits open, **an interference pattern** of the slits, in the screen area behind the slits of photon collisions between the two slits is observed.

These observations have been interpreted as unequivocal evidence for a photon's dual behaviors as **both** a particle **and** a wave. This became a key cornerstone of quantum mechanics (QM).

In his forthcoming book⁽¹²⁾, Omura properly points out that "slowing down the rate of photon-firing to one quantum at a time so that no two photons can interact with each other to create an in-flight interaction (and thus an interference pattern á la Young). So how can such a photon interference pattern be observed because only one particle was present in the experimental apparatus at any given time"?

B. To answer the foregoing question, let us shift our attention to this author's research results on psychoenergetic science⁽⁴⁻⁶⁾ and D-space/deltron/R-space interactions. From these references one finds that a more appropriate reference frame (RF) than spacetime-only for the founding fathers of QM to have used, before embarking on the QM adventure, would have been a biconformal or duplex RF comprised of two, 4-dimensional, reciprocal subspaces, one of which is spacetime. The reciprocal symmetry of such a subspace pair has the unique advantage that a material property in one subspace has an equilibrium thermodynamic conjugate property in the reciprocal subspace (R-Space) given by a deltron-coupler-modified, Fourier Transform pair relationship⁽¹³⁾. In References 4 and 5, a variety of one-dimensional to three-dimensional spacetime objects have been utilized for mathematical calculations of the reciprocal-space conjugates for the special case of complete coupling.

The one-dimensional example is shown in Figures 6(a) and 6(b).

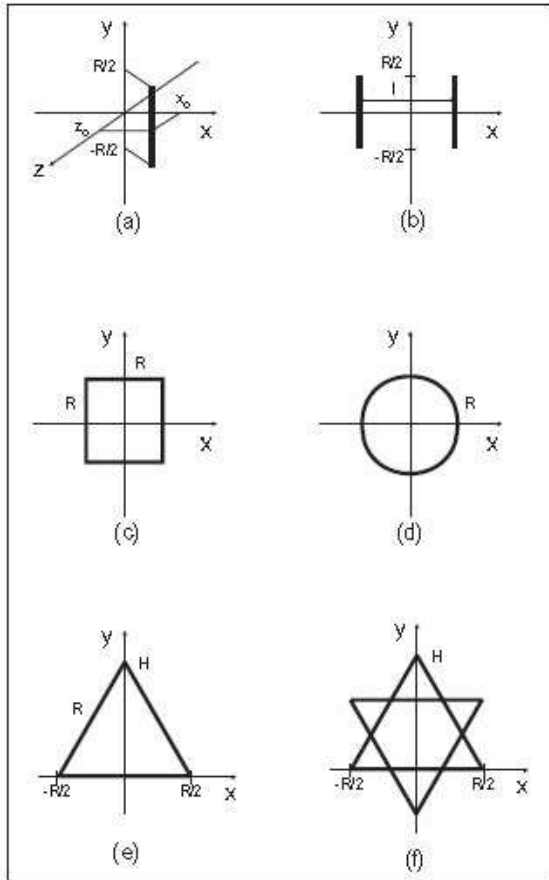

(a)

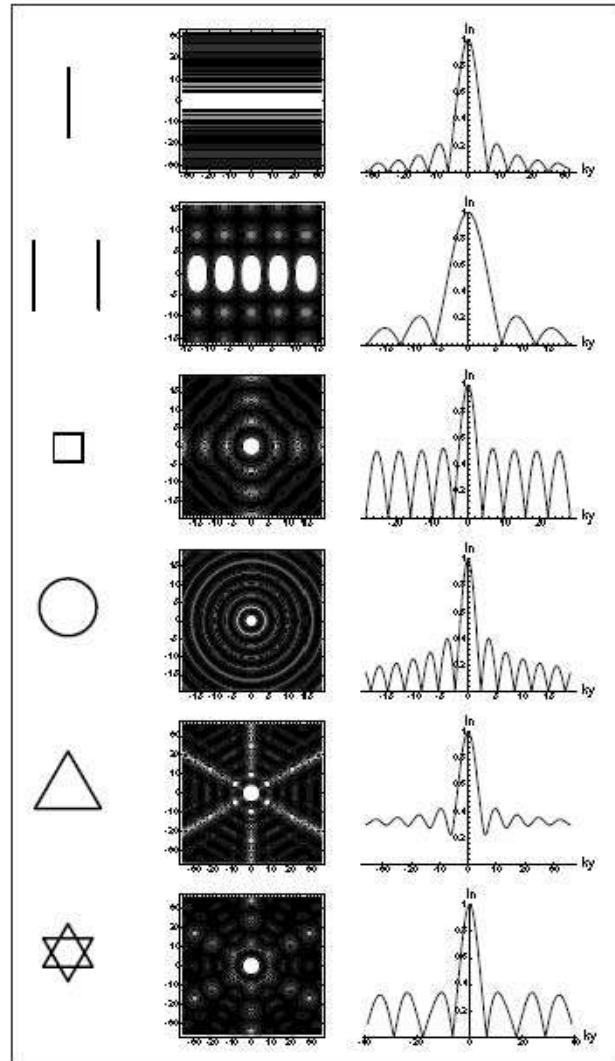

(b)

Figure 6. (a) Various 1-dimensional slit geometries (wire geometries) in D-space for which Fourier Transform representations in R-space have been calculated. (b) Comparison plots of normalized modulus, I_n , for all six 1-D objects vs. (k_x, k_y) maps in the middle column and vs. a k_y or k_n plot in the right column.

In Figure 6(b), the central column gives a section plot (or contour plot) of $I_n(k)$, a normalized modulus plot as a function of the R-space coordinates k_x and k_y with y being the vertical direction and x being the horizontal direction (see Figure 6(a)) for the corresponding shape on the left. The right hand column provides a cut through this figure along the k_y -coordinates for all shapes. These plots all correspond to the diffraction pattern of the object shape under consideration.

For the single rod (or slit), the k_y -direction in R-space is colinear with the y -direction in D-space and each oscillation in the modulus, I_n , decays in amplitude as one moves from the center of the slit to either end. Increasing the length of the slit (rod) reduces the size of the undulation intervals, Δk_y , for the bumps in the I_n profile.

For the **two parallel rods (slits)**, displaced from each other by a distance ℓ in the x -direction, a phase-difference of e^{ik_x} exists between them. This causes the second slit (rod) to **interfere** with the first to produce a dominant oscillation in I_n along the k_x -direction. For any other polyhedral-shaped rod/slit type of object, parallel segments produce R-space oscillations in the orthogonal directions. (Reference 4, pages 253 to 270 plus the chapter appendices provide abundant additional detail on this topic).

For our purpose, here, the important point to engage the reader's attention is that the above results are remarkably like the classical double-slit experiment of Young for photons (or electrons).

"Whereas a single vertical slit gives a uniform intensity on the screen behind the central region of the slit, a double-slit exhibits a typical interference phenomenon on the screen behind and along a line between the two slits" (the x -direction in Figure 6(a)).

Perhaps what is actually happening in the Young double-slit experiment is that the R-space information pattern of the single and double slit case actually interacts with the photons and guides them to their collision sites on the screen.

This would certainly account for Omura's^(12a) observation associated with time-separated, single photon events wherein only one photon was present in the apparatus at a time, yet an interference pattern is present!

This postulate could be seriously tested experimentally by anyone with the necessary apparatus because the details of the photon distribution should mathematically conform to both the **spacing**, ℓ , of the two slits plus their length, L , plus other slit shapes, etc.

When one **complicates**/refines the double slit apparatus with two holes to actually see which hole the photon or electron goes through, the particles behave in a single slit fashion⁽¹⁴⁾.

Further, such an experimental apparatus may be a suitable vehicle for investigating the "deltron-coupler effect" on the R-space pattern detection.

D. An R-space Vector Mathematical Description of the "Remote Viewing" Phenomenon

Julian Schwinger⁽¹⁾, along with Feinman and Tomonaga, shared the Nobel Prize for their discovery and mathematical development of quantum electrodynamics (QED). Schwinger had a Ph.D. student, Paul Werbos, who made the very prophetic points⁽²⁾ that (1) all forms of QED: Copenhagen, Bohmian, Schwinger-type or Werbos-type yield the same kind of predictions and **none of them** can explain the

psychoenergetic phenomenon “remote viewing” and (2) he tells us that the various military establishments of the world have spent billions of dollars using QED to try and “see” things very far away and they have completely failed to do so!

The point, here, is that our present formulation of quantum mechanics (QM), great as it is, is totally inadequate to encompass the inclusion of psychoenergetic phenomena into our scientific worldview, thus, it is time to formulate a larger perspective, or reference frame (RF), for viewing nature that **both** accounts for all of the old successful data **and** also provides the possibility of quantitatively accounting for this new psychoenergetic data in a self-consistent way.

In this regard, Karl Pribram’s holonomic theory⁽¹⁵⁾ of brain processing appears to be based on a very slight modification of the **Fourier Transform** duality concept between spacetime information patterns and spectral domain information patterns. His experimental data strongly indicates that cortical neurons of the brain act like individual receiving antennae in a large array which converts spacetime information into a diffraction pattern whose mathematical representation is very close to the Fourier Transform of the incoming spacetime information.

This information conversion to the frequency domain appears to be ideal for subsequent brain processing and brain perception. Of course, the brain must also contain an **inverse** Fourier Transform processor so that our consciousness perceives the outer world structures to be just as we currently think we do.

From a pictorial perspective, one can readily illustrate the structural changes associated with repeated Fourier Transformations in a given direction. These are illustrated in Figure 7 where T represents the Fourier Transformation (clockwise change) while T^{-1} represents the inverse Fourier Transformation (a counter-clockwise change).

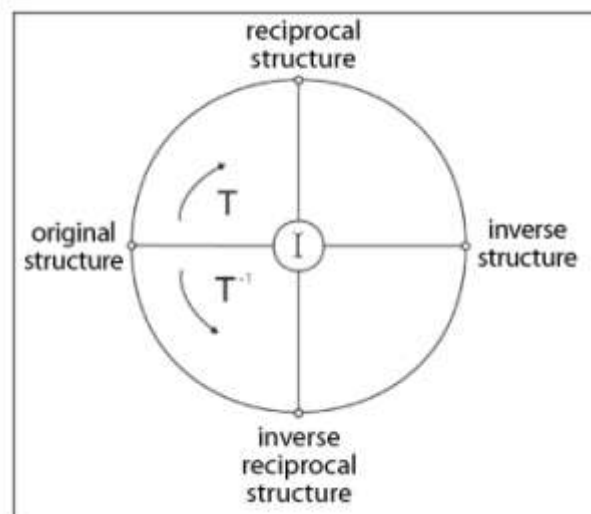

© William A Tiller – May 2015 - www.tiller.org

Figure 7. Structural changes associated with repeated Fourier Transformations in a given direction (T = clockwise and T^{-1} = counterclockwise).

From a mathematical perspective, the transformation pair T, T^{-1} for the one-dimensional case can be simply written as

$$T : F(k) = \frac{1}{(2\pi)^{1/2}} \int_D f(x) e^{i2\pi x \cdot k} dx, \quad (5a)$$

$$T^{-1} : f(x) = \frac{1}{(2\pi)^{1/2}} \int_R F(k) e^{-i2\pi x \cdot k} dk. \quad (5b)$$

The transformation, T, involves the use of the phase operator $\exp(i2\pi xk)$, while the inverse transformation requires using the reverse phase operator $\exp(-i2\pi xk)$. One is a clockwise rotation while the other is a counter-clockwise rotation. One clockwise rotation of a one-dimensional object, $f(x)$, with spatial coordinate x converting it to a frequency coordinate, (k) , representation of the object, $F(k)$, called the reciprocal object which can have mathematically real and imaginary parts. One repeated clockwise transformation, \tilde{I} , represents the operation of inversion ($T^2 = \tilde{I}$ and with $i^2 = -1$). Four such rotations represents the operation of identity (since $T^4 = 1$ and $i^4 = +1$).

In our orthodox science QM paradigm, spacetime-only is the reference frame (RF) used but, to do so, simultaneous particle and wave behavior of all things must be assumed. This created a major philosophical problem for the founding fathers of QM that still exists today, almost a century later. In addition, the psychoenergetic science experiments of Chapters 3 to 5 of Reference 5 have unequivocally shown that human consciousness via focused human intention can significantly influence the properties of materials (inorganic and organic plus in vitro and in vivo).

The key step made by the author of Reference 6 to solve this philosophical problem was to propose an expansion of our RF to a coupled **duplex** RF consisting of reciprocal, 4-dimensional subspaces, one of which is spacetime. Returning to Figure 7, this proposal allows the two ends of the single T-transformation to co-exist as in Figure 8 with the RF for particles being direct space (D-space or (x,y,z,t) -space or spacetime) and simultaneously, the RF for the waves being reciprocal space (or R-space, the physical vacuum space or $(k_x, k_y, k_z, 1/t)$ -space).

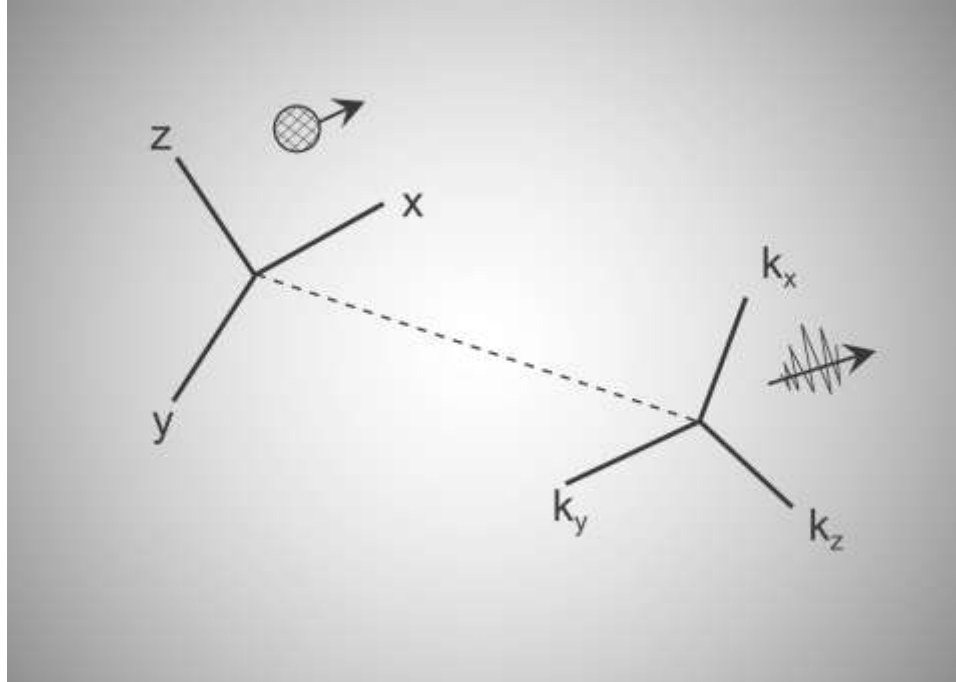

Figure 8. Adoption of the 8-dimensional duplex space as a basis for physical reality would produce a particle and wave simultaneity viewpoint with the RF of the particles being direct space (D-space or x,y,z,t -space or spacetime). The RF for the waves is labeled reciprocal space (or R-space) or (k_x,k_y,k_z,k_t) -space.

The unique advantage of such a relationship is that, with the addition of a “deltron” coupler⁽⁵⁾, a physical property in D-space has a **conjugate** property in R-space given thermodynamically by a deltron-modulated, Fourier Transform relationship such as illustrated via Figure 9^(5,6,16).

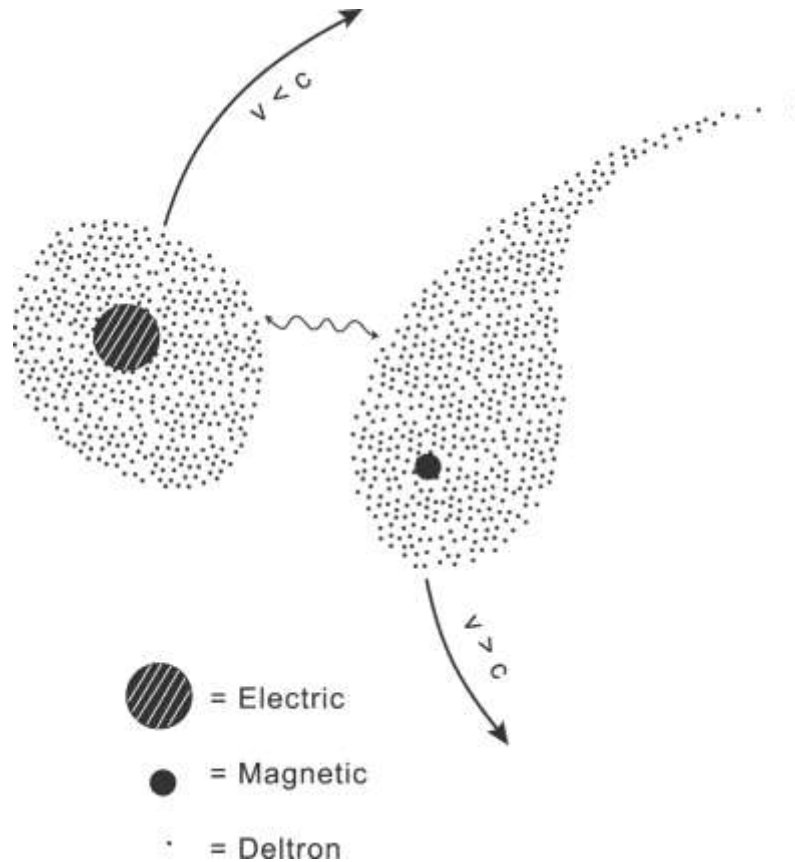

Figure 9. A higher dimensional level substance, labeled deltrons, falling outside the constraints of relativity theory and able to move at velocities $v \leq c$, acts as a coupling agent between the electric monopole types of substances and the magnetic monopole types of substances to produce both electromagnetic (EM) and magnetoelectric (ME) types of mediator fields exhibiting a special type of “mirror principle” relationship between them.

When the deltron coupler concentration is shrunk to zero, these two subspaces are decoupled and we are left with the classical physics picture of a spacetime-only RF; however, when the deltron coupler grows in magnitude, then the QM physics behavior begins to present itself to our world and one can begin to appreciate the importance of human consciousness manifestations in natural phenomena.

The addition of the deltron coupler to our physics concepts increases the magnitude of human-human connectivity as well as human-device connectivity⁽⁵⁻⁷⁾. In fact, we can now begin to see how non-local phenomena are operational in spacetime (D-space) via its connectedness with all of R-space and vice versa. It also explains the robust experimental data of References 5,6 and 7. This can now be illustrated via the psychoenergetic phenomenon of **remote viewing**.

Remote Viewing by a Human at Spatial Coordinate (0,0,0,t) and a Physical Object at Coordinates (x,y,z,t)

It is well known that any 3-dimensionally-shaped object, $f(x,y,z,t)$ can be fully described by a 3-dimensional Fourier Transform, $F(k_x, k_y, k_z, k_t)$. Given by

$$F_R(k_x, k_y, k_z) = \frac{1}{(2\pi)^{3/2}} \int_D f(x, y, z) e^{i2\pi s \cdot k} ds \quad (2a)$$

where s represents (x,y,z) as the D-space coordinates. $F_R(\underline{k})$ is the **conjugate** R-space object description at the distant (x,y,z) location. The modulus, \tilde{I}_R , of this Fourier Transform at this remote location is given by

$$\tilde{I}_R = (F_R F_R^*)^{1/2} \quad (2b)$$

where F_R^* is the complex conjugate of F_R (which is found by replacing all $i = \sqrt{-1}$, the imaginary quantity symbol, by $-i$). This operation converts \tilde{I}_R to a mathematically real quantity with a total value, Q_R , given by

$$Q_R = \int_R \tilde{I}_R(\underline{k}) d\underline{k} \quad (2c)$$

where \underline{k} ranges over the entire frequency domain, (k_x, k_y, k_z) of R-space.

The operational psychoenergetic process of remote-viewing by a person at D-space location (0,0,0) requires the following steps:

- (1) Calling the remote R-space location, R_1 , and the local observer's R-space location, R_0 , one must first translate $F_{R_1}(k_x, k_y, k_z)$ to $F_{R_0}(k_x, k_y, k_z)$, which is mathematically given by

$$F_{R_0}(k_x, k_y, k_z) = \exp(ix+jy+lz) F_{R_1}(k_x, k_y, k_z) \quad (3a)$$

- (2) If one also wishes to view the distant object from different angles, an (x,y) rotation by angle θ , say, then $F_{R_0}(k_x, k_y, k_z)$ becomes $F_{R_0}(k'_x, k'_y, k_z)$ where

$$k'_x = k_x \cos\theta + k_y \sin\theta$$

and

$$k'_y = k_x \sin\theta + k_y \cos\theta \quad (3b)$$

- (3) Finally, $F_{R_0}(k'_x, k'_y, k_z)$ must be transformed back to the D-space representation via using the inverse Fourier Transform (T^{-1}) as in

$$f(0,0,0) = \frac{1}{(2\pi)^{3/2}} \int_R F_{R_0}(k'_x, k'_y, k_z) e^{-i2\pi s \cdot k} dk \quad (4)$$

- (4) Any time-change considerations are dealt with in the same fashion via replacing s with t .

The foregoing steps, 1 to 4, provide a mathematical sequencing for the transformation of the non-local D-space object, $f(x,y,z,t)$, to the viewer's conscious mind in the form of $f(0,0,0,t)$. The actual **inner** human work to do this occurs at the human unconscious mind or R-space level. It is assumed that, with sufficient training and practice, most (if not all) humans are eventually able to do this as abundant experimental data shows. Further, from a QM-perspective, if the founding fathers had **first** transformed our spacetime-only RF to this particular duplex RF, QM development would have been greatly enriched and enhanced!

E. Material Property Oscillations and Their Coupled Behavior

In Reference 4, Chapter 6, pages 172 to 205 and time period ~May, 1999, in a laboratory near Minneapolis, it was observed that, in an IHD-conditioned space to what we think was the SU(2) Gauge symmetry state level, material properties like air and water, temperature and water pH begin to oscillate in the sub-Hertz range ($\sim 10^{-1}$ to 10^{-6} Hertz). Moreover, the frequencies of all three measurements are identical (the Fourier Transforms absolutely nest, one with the others). Whereas, in our normal U(1) Gauge symmetry state, such an oscillatory behavior never happens. In addition, it appears that the whole room and everything in it oscillates in this way. Figure 10a illustrates how the air temperature-oscillations throughout the room nest while Figure 10b illustrates how both the water temperature-oscillations and the pH-oscillations nest with each other.

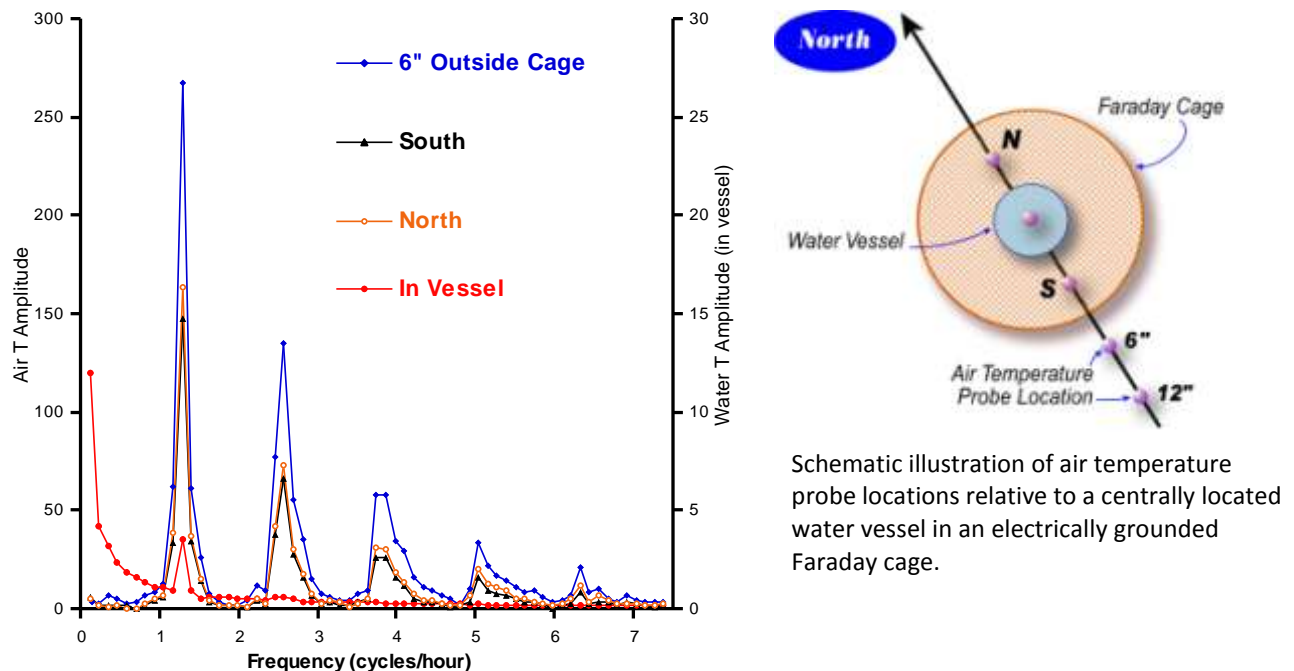

Figure 10a. Fourier transformed amplitude spectra data for 9-17.5 hour interval of Figure 10b. The fundamental period is 46.5 min. and five harmonics are observed.

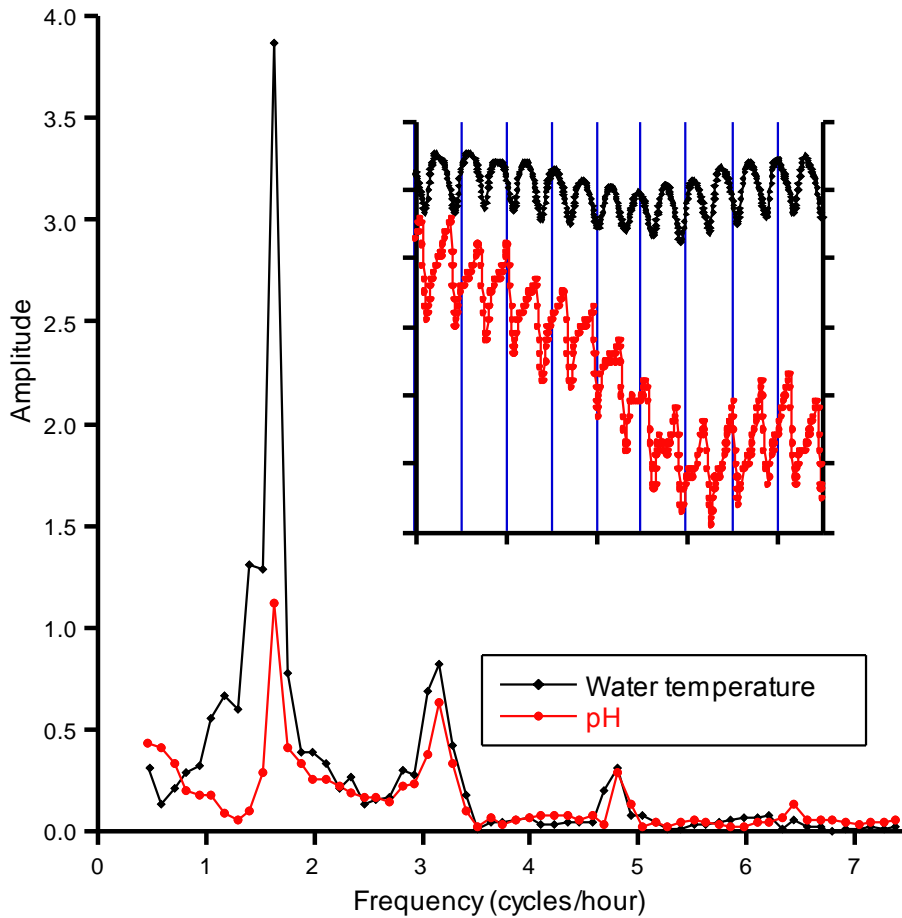

Figure 10b. Fourier Transform comparison of both water T-oscillation and pH-oscillation data in the water vessel on 5/10/99. Real-time oscillation data shown in inset. The fundamental period is 36.6 min. and three harmonics can be easily discerned.

In addition, in Reference 4, pages 202 to 204, when a 6" long natural crystal was placed in the center of the Figure 10a Faraday cage with its c-axis pointing in the vertical direction, the air temperature wave train oscillations located some distance away looked as Figure 11a while, when the orientation of the crystal was shifted to the horizontal orientation at that location, this group of air temperature wave train oscillations immediately inverted its overall shape as in Figure 11b.

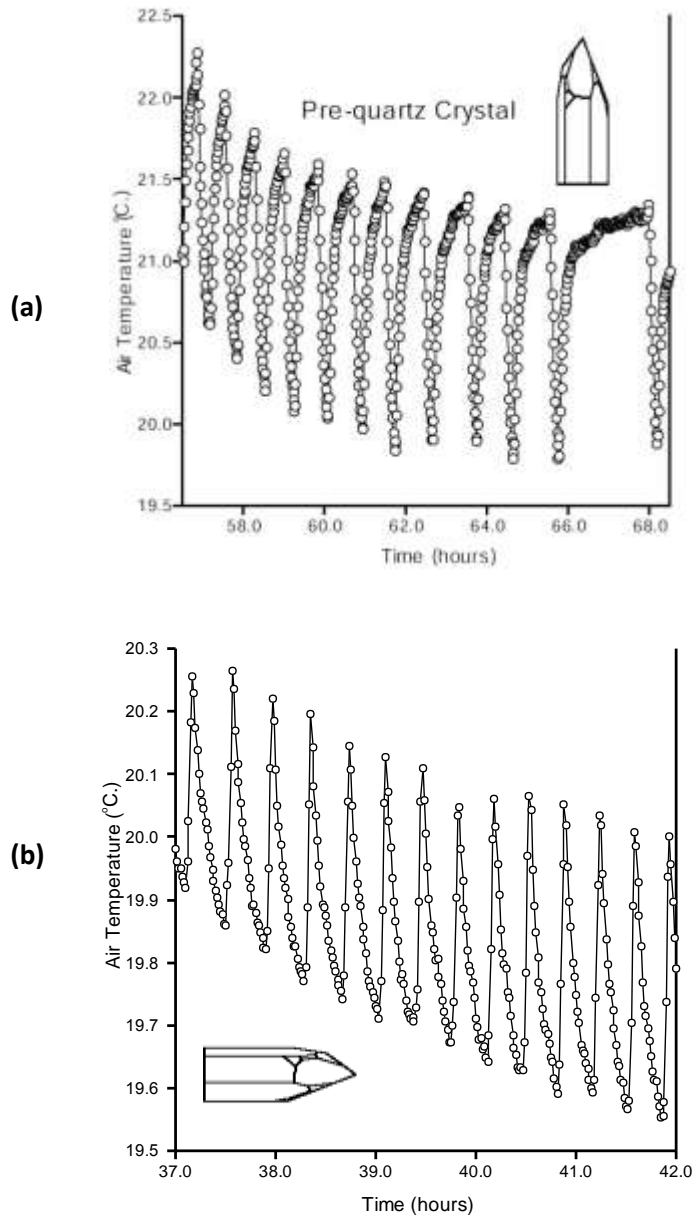

Figure 11a & b. Comparison of air, T-oscillation amplitude, frequency and waveform between the pre-quartz crystal condition and the condition immediately after changing the orientation of the quartz crystal to the c-axis horizontal position.

Clearly, there appears to be some weird material property behavior occurring in IHD-conditioned spaces. Starting in May of 2012 in an IHD-conditioned laboratory located in Payson, Arizona, we discovered a new macroscopic entanglement phenomenon when measuring both pH and air temperature simultaneously in a ~5 foot cubic box with mu-metal walls. These mu-metal walls have a very high magnetic permeability which diverts magnetic flux lines **into** the metal walls so as to

significantly lower the total magnetic field intensity in the interior of the box. The two independent measurement apparatus are shown in Figure 12. One measurement system involved a laptop attached via USB cable to a digital thermometer⁽¹⁷⁾. The other measurement system used its own laptop connected to a pH measurement device via a PCMCIA card (Sensorlink). In the Figure 12 set-up, the two measurement systems are independent but are powered through the same electrical outlets located outside the box.

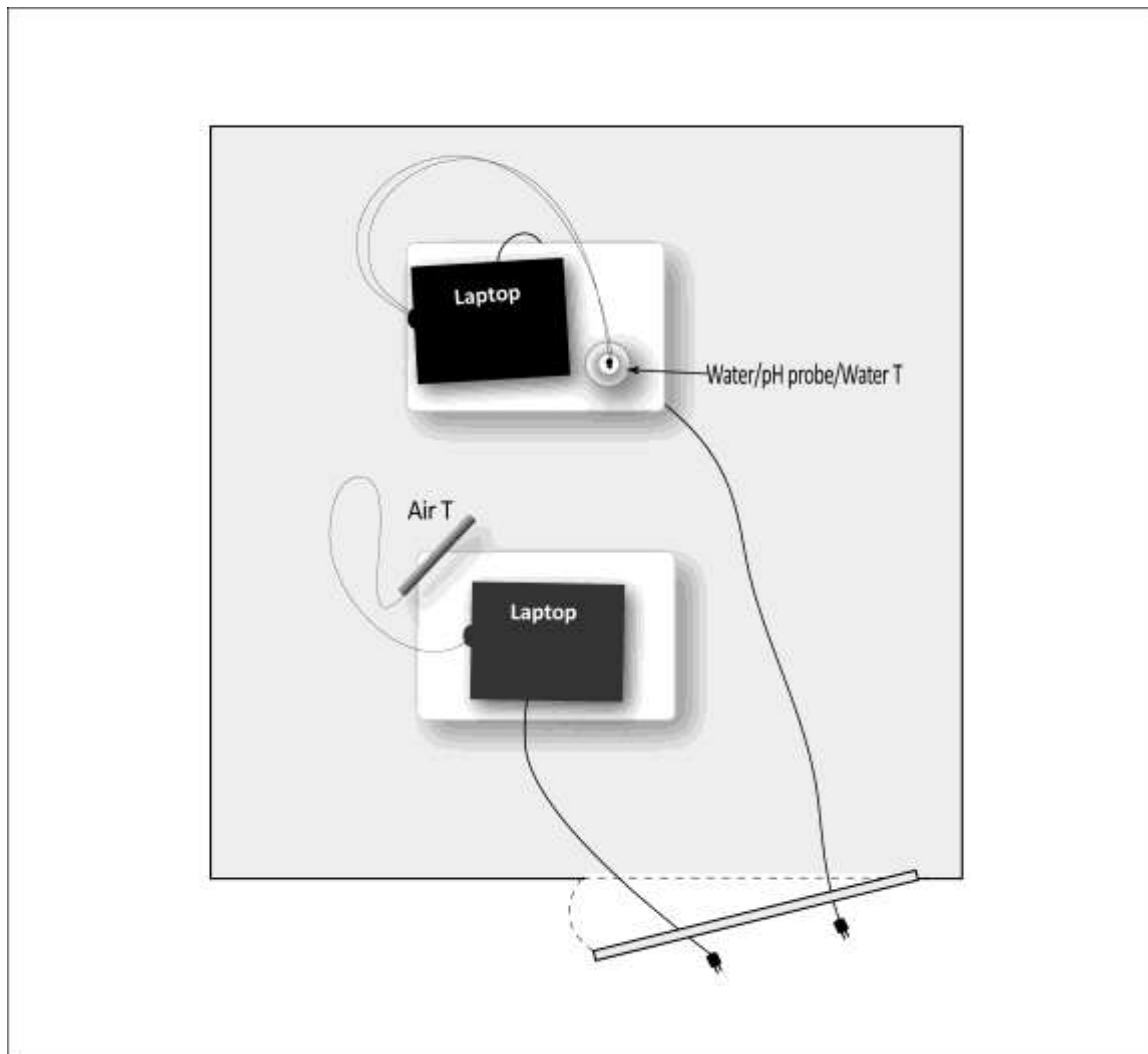

Figure 12. Schematic illustration of Mu-Box experimental set-up.

The air temperature oscillations of interest in this experiment are superimposed on the diurnal air temperature variation which can exhibit high amplitudes since there was no air-conditioning or heating involved. In performing an analysis of oscillation periodicity, we generally de-trended the data to

remove the diurnal variation by using a one-hour moving average which yields both 43 and an 86-minute periodicities in the raw data as illustrated in Figure 13.

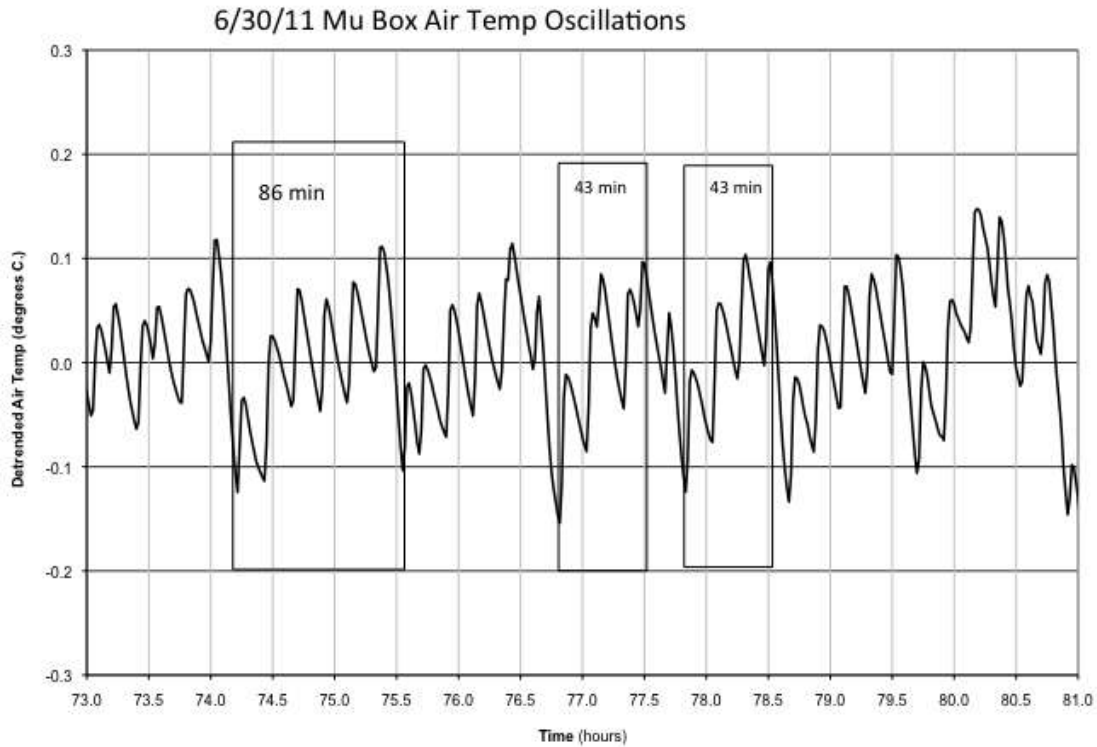

Figure 13. De-trended temperature vs. time.

A Fourier Transformation of this Figure 13 was utilized to provide a more complete picture. This analysis was for a time interval of 6 days using a sample interval of one minute (8640 data points) with the pH-measurement system simultaneously running.

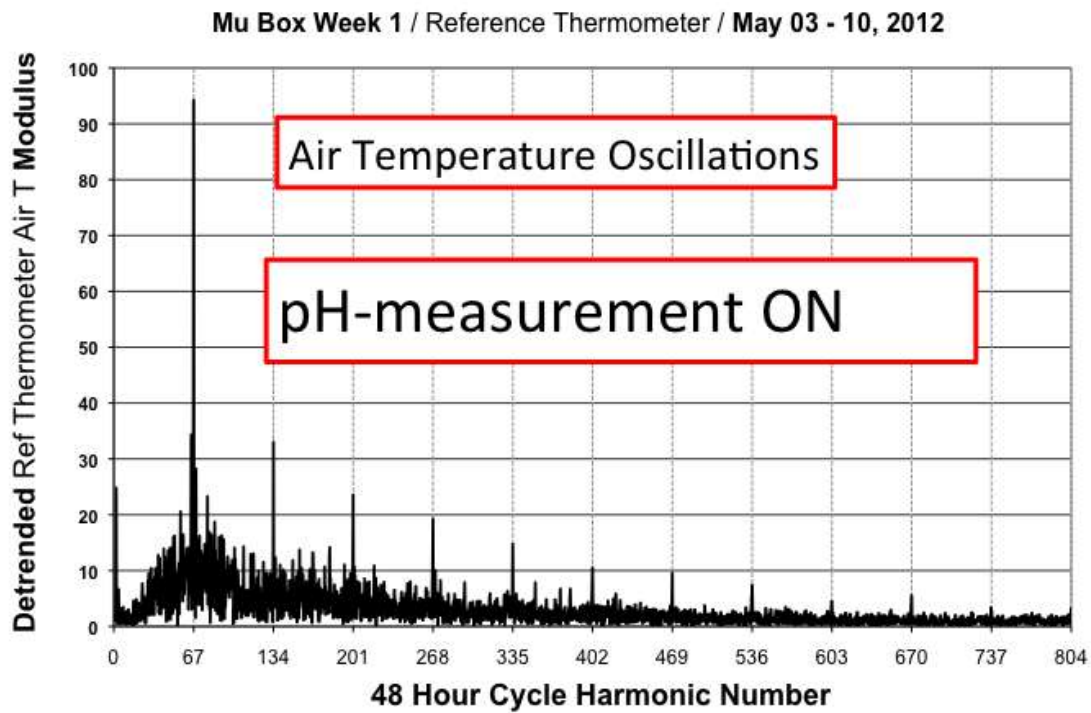

Figure 14a. Modulus vs. 48-hour cycle harmonic number.

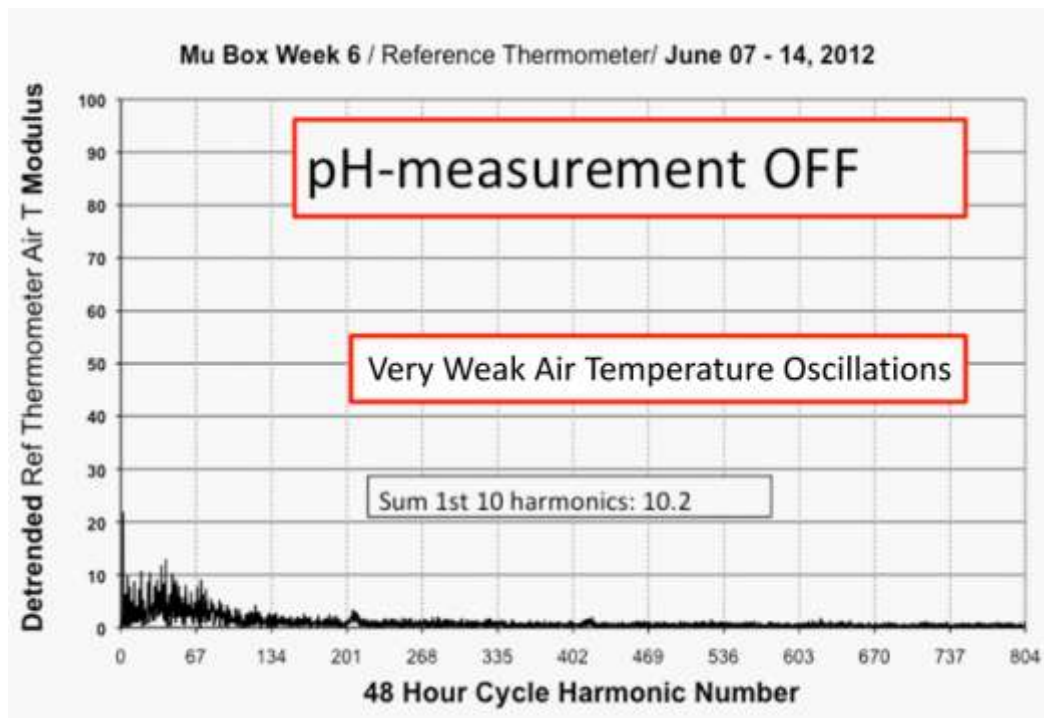

Figure 14b. Modulus vs. 48-hour cycle harmonic number.

Figure 14a shows that this air temperature data has a period that is the 67th harmonic of the 48 hour cycle. This period is about 43 minute (2880 minutes in 2/67 days). There are also numerous harmonics of this fundamental frequency (0.00038773 Hz). Note that the first 10 harmonics are particularly strong.

An important discovery was noted when we just turned off the pH measurement system for a period of time (see Figure 14b). Suddenly, the de-trended air temperature modulus greatly decreased in amplitude! Merely pressing an off-button on the pH-software’s screen interface window accomplished this feat.

To quantify the air-oscillations magnitude, we summed the modulus values for the first ten harmonics shown in Figure 14a. for each week of a long pH-on/pH-off experiment, these modulus sums were recorded both for the time periods the pH was also being recorded and when it was not being recorded. Figure 15a shows the initial results while Figure 15b shows 5 on/off cycles of data gathered over a 10 month experiment.

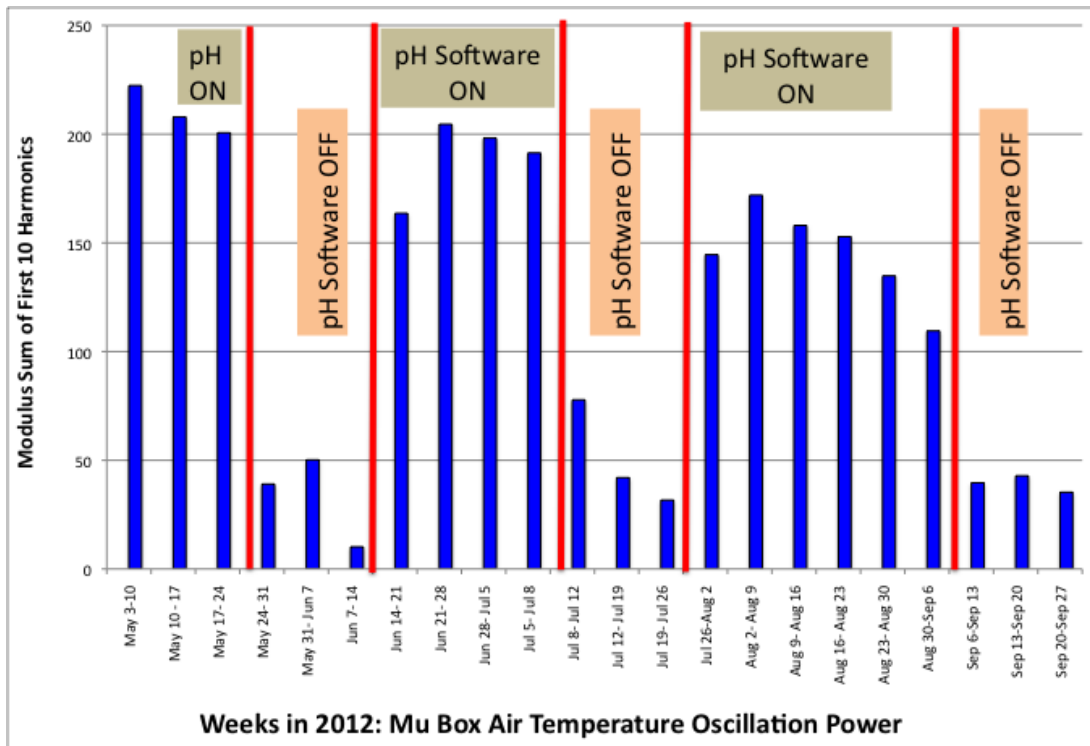

Figure 15a. Modulus sums (power) for each week of the experiment.

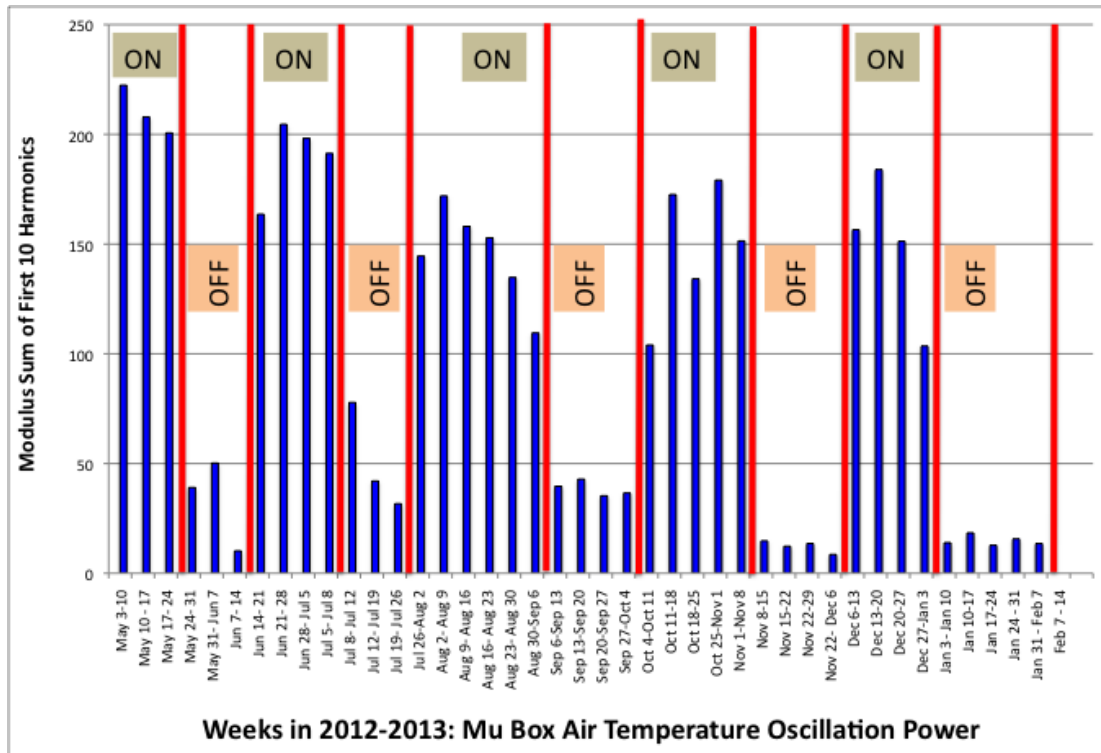

Figure 15b. Modulus sums (power) for each week of the experiment over 10 months and 5 on/off cycles.

One can speculate on the many possible factors influencing the data behavior demonstrated by Figures 15a and 15b. However, this would greatly extend the purpose of adding this topic example to White Paper XXXIX. Thus, we will restrict our attention to the unquestionable entanglement of the pH and temperature measurement systems and propose that this is yet another example of vector behavior of a larger system to be seriously looked at from the perspective of Figures 4 and 5. We presume that Figures 15a and 15b, respectively, refer to the pH-vector being “on” in the system vs “off” in the system.

References

1. J. Schwinger, Particles and Sources (Gordon and Breach, Science Publishers, New York, NY, 1969).
2. P. Werbos, “What do neural nets and quantum theory tell us about mind and reality” in No Matter, Never Mind, eds. K. Yasue, M. Jiba and T.D. Senta (John Benjamins Publishing Co, Philadelphia, PA, 2001).

3. W.A. Harrison, Applied Quantum Mechanics (World Scientific, Singapore, 2000).
4. W.A. Tiller, W.E. Dibble Jr. and M.J. Kohane, Conscious Acts of Creation: The Emergence of a New Physics (Pavior Publishing, Walnut Creek, CA, 2001).
5. W.A. Tiller, Psychoenergetic Science: A Second Copernican-Scale Revolution (Pavior Publishing, Walnut Creek, CA, 2007).
6. W.A. Tiller, Science and Human Transformation: Energies, Intentionality and Consciousness (Pavior Publishing, Walnut Creek, CA, 1997).
7. R.M. Eisberg, Fundamentals of Modern Physics (John Wiley and Sons, Inc, New York, NY, 1961).
8. R.V. Churchill, Introduction to Complex Variables and Applications (McGraw-Hill Book Company, Inc, 1948).
9. W.A. Tiller, "What does the Dirac energy sea mean and why has today's orthodox physics neglected it?", online document, www.tiller.org, White Paper #VI.
10. W.A. Tiller, "Why CAM and orthodox medicine have some very different science foundations", online document, www.tiller.org, White paper #III.
11. M. Enserink, "Can the Placebo be the Cure?", *Science*, 284, 238-240, 1999.
12. (a) W. Omura, Evolutionary Consciousness (to be published, 2015);
(b) R. Feinman, L. Leighton and M. Sands, The Feinman Lectures on Physics, Vol 2 (Reading MA; Addison-Wesley, 1981) p 1.
13. W.A. Tiller, online documents. www.tiller.org, White Paper #XXXVII.
14. J. Gribbin, In Search of Schroedinger's Cat (Bantam Books, Inc, New York, NY, 1984) p 171.
15. K. Pribram, Brain and Perception, Holonomy and Structure in Figural Processing (Lawrence Erlbaum Associates, Hillsdale, NJ, 1991).
16. W.A. Tiller, W.E. Dibble, Jr. and J.G. Fandel, Some Science Adventures with Real Magic (Pavior Publishing, Walnut Creek, CA, 2003).
17. USB Reference Thermometer Model #USB-REF from Thermoworks, www.thermoworks.com.

Appendix I, Relevant Mathematics for the Placebo Effect

Here, we use Figure 4 as the most general example of a D-space medical interactive relationship and use it as a pedagogical vehicle for generating the R-space equilibrium counterpart for such a system event.

With \underline{r} representing the D-space general spatial coordinate and \underline{k} representing the R-space general spatial wave number, the Fourier Transform pair relationship for a D-space shape of the form $f(\underline{r})$ is given by

$$F(\underline{k}) = \frac{1}{(2\pi)^{3/2}} \int_{-\infty}^{\infty} f(\underline{r}) e^{i\underline{r} \cdot \underline{k}} d\underline{r}, \quad (1-1a)$$

and

$$f(\underline{r}) = \frac{1}{(2\pi)^{3/2}} \int_{-\infty}^{\infty} F(\underline{k}) e^{-i\underline{r} \cdot \underline{k}} d\underline{k}. \quad (1-1b)$$

With a deltron activation function of $C_\delta(\underline{r})C_\delta'(\underline{k})$, the deltron-empowered Fourier Transform pair relationship for a D-space subsystem in the overall system is given by

$$G(\underline{k}) = F(\underline{k})C_\delta'(\underline{k}) = \frac{1}{(2\pi)^{3/2}} \int_{-\infty}^{\infty} f(\underline{r})C_\delta(\underline{r}) e^{i\underline{r} \cdot \underline{k}} d\underline{r} \quad (1-2a)$$

and

$$G'(\underline{r}) = f(\underline{r})C_\delta(\underline{r}) = \frac{1}{(2\pi)^{3/2}} \int_{-\infty}^{\infty} F(\underline{k})C_\delta'(\underline{k}) e^{-i\underline{r} \cdot \underline{k}} d\underline{k}. \quad (1-2b)$$

This is how an **equilibrium** R-space conjugate is formed for a given D-space geometrical shape, $G'(\underline{r})$, in the partially coupled state of physical reality when the deltron activation function is separable into the $C_\delta(\underline{r})C_\delta'(\underline{k})$ form.

To obtain the $\alpha_{\text{eff}}Q_m$ term in Equation 2 of the main text, we first evaluate the intensity, $I(\underline{k})$, and integrate it over all of R-space to obtain Q_m . Then, we take general expansions of $C_\delta(\underline{r})$ and $C_\delta'(\underline{k})$ and make a zeroth order approximation to obtain α_{eff} . Proceeding,

$$I(\underline{k}) = G(\underline{k})G^*(\underline{k}) \quad (1-3a)$$

and

$$\alpha_{\text{eff}}Q_m = \int_{-\infty}^{\infty} I(\underline{k})d\underline{k}. \quad (1-3b)$$

Here $G^*(\underline{k})$ is the complex conjugate of the vector $G(\underline{k})$.

Turning now to Figure 5 of the main text, there is only one component to Q_e in equation 1 of the main text but 5 vector components for the R-space counterpart. Setting α_{eff} = the space gauge symmetry component, we now have Q_M being determined by the other four vector contributions defined, with

subscripts P, D, C and U to represent, respectively, practitioner, device, client and unseen. Therefore, the system vector, $R_s \exp(i\theta_s)$, is given by the vector sum

$$R_s(\underline{k})e^{i\theta_s(\underline{k})} = R_p(\underline{k})e^{i\theta_p(\underline{k})} + R_D(\underline{k})e^{i\theta_D(\underline{k})} + R_C(\underline{k})e^{i\theta_C(\underline{k})} + R_U(\underline{k})e^{i\theta_U(\underline{k})}. \quad (1-4)$$

The system intensity, $I_s(\underline{k})$, is given by

$$I_s(\underline{k}) = R_s(\underline{k})e^{i\theta_s(\underline{k})} R_s(\underline{k})e^{-i\theta_s(\underline{k})} = R_s^2(\underline{k}) \quad (1-5a)$$

$$= [R_p^2 + R_D^2 + R_C^2 + R_U^2]$$

$$+2 \left\{ \begin{array}{l} R_p R_D \cos(\theta_p - \theta_D) + R_p R_C \cos(\theta_p - \theta_C) + R_p R_U \cos(\theta_p - \theta_U) + \\ R_D R_C \cos(\theta_D - \theta_C) + R_D R_U \cos(\theta_D - \theta_U) + R_C R_U \cos(\theta_C - \theta_U) \end{array} \right\} \quad (1-5b)$$

In equation 1-5b, the coordinate, \underline{k} , has been left out for simplicity. The important point to note here is that, in the system intensity, which is all that one can expect to measure, we have 6 pairwise terms indicating that each term is connected to each other term and each subsystem has three neighboring interactions. For example, let us let the device be replaced by a placebo so that we can represent $I_s(\underline{k})$ by

$$I_s(k) = A + 2R_D \left\{ R_p \cos(\theta_p - \theta_D) + R_C \cos(\theta_D - \theta_C) + R_U \cos(\theta_D - \theta_U) \right\} \quad (1-6)$$

where A is determined by subtracting equation (1-6) from (1-5b). Thus, even if R_D has only a nominal value, the bracket that multiplies it can be very large so its activity effect in the system can be appreciable. This is how, in a typical doctor, treatment, placebo, subjects randomized clinical trial, the placebo group can **never** be isolated from the treatment group. Further, the magnitude of the placebo effect depends on the size of the doctor effect, the treatment effect, the subject effect and the unseen effect.

If one is using just one subject (client) with the practitioner using a testing device on the subject and one brings a sequence of food supplements, X, say, into the field of the experiment, a series of new terms will enter $I_s(k)$, one for each of the other R-space subsystems in the overall system. In principle, one can use such a testing procedure to determine beneficial vs. harmful reactions of the R-space aspect of X upon the R-space aspect of the client.

The Mystery Megaliths of Colombia

(in the Land of El Dorado)

By David Hatcher Childress

In February of 2015 I made a journey to Colombia with my wife Jennifer and some members of the World Explorers Club. I have travelled widely in South America, but had never been to Colombia. With the guerilla war going on for years, and the violent narco-terrorism, Colombia was something of a forbidden zone for decades. It seemed like the last guy to go adventuring in Colombia was Jack from the movie *Romancing the Stone*.

The famous drug kingpin Pablo Escobar, known as the richest criminal in the world, offered to pay off the Colombian national debt in 1989 in a bid for legitimacy, but was finally killed in a shootout with the Colombian army in Medellin in 1993. The Cali cartel took over his lucrative drug trade but it was largely quashed by 2005.

In the last few years, Colombia has settled down to become a prosperous—and largely peaceful—country, with a growing tourist industry. Colombia is a mountainous and ethnically diverse country. It was one of the earliest areas of Spanish exploration, with the Admiral Alonso de Ojeda (who had been one of the early crew with Columbus) landing on the coast in 1499.

By the year 1533 the important port of Cartagena was founded, and before that the ports of Santa Maria la Antigua del Darien (1510) and Santa Marta (1525) were in use.

By April of 1536 the Spanish conquistador Gonzalo Jiménez de Quesada led an expedition to the interior and christened the districts through which he passed the “New Kingdom of Granada.” Marching inland in August 1538, he founded the city of Santa Fé de Bogota as the capital. During this same period the conquistador Sebastián de Belalcázar, conqueror of Quito, an Inca capital, traveled into what is now Colombia and founded Cali (1536), and then Popayan (1537). The German conquistador Nikolaus Federmann crossed the mountains of the Llanos Orientales and went over the Cordillera Oriental during the years 1536 to 1539, spurred on by the persistent legend of El Dorado, the “city of gold.”

This legend of a city of gold, and the many gold artifacts found in Colombia, continued to play a pivotal role in luring explorers from all over Europe to New Granada during the 16th and 17th centuries. Their goal was to find the fabled lost city of unimaginable wealth.

El Dorado: The City of Gold

Starting in 1535, the German conquistadors [Georg von Speyer](#) and [Nikolaus Federmann](#) searched the Venezuelan lowlands, then into the Colombian plateaus, and then the Orinoco Basin for the lost city of gold. Tradition had the gold city on an island, presumably in the jungles of the Amazon basin, which was yet to be explored—and remains today a vast area of little-known land. Federmann and von Speyer completely missed the megalithic sites of San Agustin and Tierradentro, which were high in the mountains and long lost to history. They would not be discovered until hundreds of years later.

Von Speyer was later accompanied by the German conquistador [Philipp von Hutten](#) on an expedition (1536-38) in which they journeyed through Colombia and reached the headwaters of the Rio Japura in southwest Colombia, near the current border with Ecuador. Hutten led an exploring party of about 150 men in 1541, mostly horsemen, from Coro on the coast of Venezuela into Colombia in search of El Dorado. This group wandered for several years, but were continually harassed by the natives and finally returned to Santa Ana de Coro in Venezuela in 1546.

The stories of a golden city drew the Spanish conquistador [Gonzalo Jimenez de Quesada](#) and his army of 800 men away from their mission to find an overland route to Peru. From 1537 to 1538 Quesada’s army moved into the Andean homeland of the Muisca people and essentially

conquered them. His men noticed that the Muisca had a large number of small gold artifacts. In September of 1540 his brother, Spanish conquistador Hernan Perez de Quesada, set out with 270 Spaniards and thousands of Indian porters to explore the Orinoco Basin, but they found no golden city—mostly hostile jungle—and returned to Bogota.

News of the gold artifacts from the Muisca area of Colombia and stories told by the natives of the special rites that took place at Lake Guatavita convinced the Spanish that a kingdom of tremendous wealth existed somewhere in the area. The rites at Lake Guatavita included the gold dusting of a king who jumped into the crater lake, as well as throwing items made of gold into the waters.

A golden city, often called “Manoa,” was thought to exist somewhere in the Amazon basin and began to appear on maps. The Amazon basin got its first thorough search starting in 1560 when the notoriously violent conquistador [Lope de Aguirre](#) joined the expedition of [Pedro de Ursua](#) down the Marañon and Amazon Rivers in search of the golden city. This time the treasure might be some of the hidden Inca treasure that was reportedly sent to the legendary final Inca stronghold known as Paititi.

Aguirre and his daughter, Elvira, joined the 1560 Ursua expedition along with 300 other Spaniards and hundreds of natives at a time just after the civil war in Peru amongst the conquistadors who had conquered Cuzco. The Ursua expedition was meant at the time to get rid of some of the more troublesome conquistadors by sending them on something of a wild goose chase in search of the City of Gold.

Aguirre proved his troublesome nature when he assassinated Ursua while on the Amazon in 1561. He then assassinated Fernando de Guzman who took control of the group after Ursua's death. Aguirre now assumed command of the group and they continued in boats down the Amazon battling natives and destroying villages as they went. At one point they battled long-haired natives, armed with powerful bows and arrows, that Aguirre believed to be women. The river was then named the Amazon after the female warriors of Greek myth.

Aguirre and 186 men finally reached the Atlantic and then sailed northward to Venezuela and seized the island called Isla Margarita by killing the Spanish governor and his officers. Aguirre had himself proclaimed a prince of Peru and the lord of Tierra Firme and Chile. He famously said: “I am the Wrath of God, the Prince of Freedom, Lord of Tierra Firme and the Province of Chile.”

Then, in the later part of 1561, Aguirre sent a letter to the Spanish monarch Philip II in which he declared Peru an independent state of which he was the ruler.

Using the Isla Margarita base and captured ships from the local government, Aguirre crossed to the mainland in an attempt to take Panama. Here he was defeated by the Spanish crown forces and withdrew. Eventually he was surrounded at Barquisimeto, Venezuela where he killed several followers who intended to capture him. He also shot and killed his daughter Elvira because he did not want her captured and defiled by the soldiers he was fighting. He was shot to death and his body was cut into quarters and sent as a warning to various cities across Venezuela.

A film was made in 1972 by the famous German director Werner Herzog called *Aguirre, Wrath of God* that starred Klaus Kinski as Aguirre and gave a realistic treatment of the incredible difficulties of the Ursua expedition and the explosive personality of Aguirre. While no city of gold was seen by Aguirre and his men, the vast nature of the Amazon basin was observed and recounted, confirming that much had yet to be discovered.

Furthermore, Aguirre and his men had been in Peru and had seen the gigantic and finely-built megalithic walls in Cuzco, Sacsayhuaman, Pisac and Ollantaytambo. These impressive structures, typically attributed to the Incas—but probably thousands of years older—and the vast gold treasures looted from Cuzco must have impressed the conquistadors a great deal. These megalithic structures probably led Aguirre and his men to believe that further megalithic cities of gold were to be discovered and conquered. Indeed, Colonel Percy Fawcett in the 1920s held a similar view.

More tales continued to come out of Colombia and the Amazon of a great country full of gold and wonderful buildings. In Wikipedia we learn that poet-priest-historian Juan de Castellanos, who had served under Jimenez de Quesada in his campaign against the Muiscas, wrote a poem titled “The Quest of El Dorad,” circa 1574, but it was not published until 1850:



An alien Indian, hailing from afar,
Who in the town of Quito did abide.
And neighbor claimed to be of Bogota,
There having come, I know not by what way,
Did with him speak and solemnly announce
A country rich in emeralds and gold...
A certain king he told of who, disrobed,
Upon a lake was wont, aboard a raft,
To make oblations, as himself had seen,
His regal form overspread with fragrant oil
On which was laid a coat of powdered gold...

Stories of the golden city continued to be told in South America and the city of Manoa continued to be featured on maps as a real place somewhere on a river in the Amazon Basin.

Manoa and Lake Parime

Around 1575 AD in Venezuela and Colombia a popular legend was told that one Juan Martinez, on his deathbed, claimed that he had visited the city of Manoa while exploring a river in the Amazon. The story went that he had been condemned to death because he had allowed a keg of gunpowder to catch fire. But friends of his allowed him to escape downriver in a canoe where friendly natives took him to a wonderful city, which was somewhere in “Guiana.” Goes the text of the widely circulated legend:

The canoe was carried down the stream, and certain of the Guianians met it the same evening; and, having not at any time seen any Christian nor any man of that color, they carried Martinez into the land to be wondered at, and so from town to town, until he came to the great city of Manoa, the seat and residence of Inga [Inca] the emperor.

The emperor, after he had beheld him, knew him to be a Christian, and caused him to be lodged in his palace, and well entertained. He was brought thither all the way blindfold, led by the Indians, until he came to the entrance of Manoa itself, and was fourteen or fifteen days in the passage. He avowed at his death that he entered the city at noon, and then they uncovered his face; and that he traveled all that day till night through the city, and the next day from sun rising to sun setting, ere he came to the palace of Inga.

After that Martinez had lived seven months in Manoa, and began to understand the language of the country, Inga asked him whether he desired to return into his own country, or would willingly abide with him. But Martinez, not desirous to stay, obtained the favor of Inga to depart.

According to Wikipedia, the fable of Juan Martinez was founded on the adventures of Juan Martin de Albuja, well known to the Spanish historians of the Conquest and who, while with the conquistador Pedro de Silva in 1570, was captured and lived with the Caribe Indians of the Lower Orinoco. It seems doubtful that he visited a palace of the “Inga” and merely saw grass huts in small villages.

As noted above, the fabled City of Gold was featured on maps of South America in the 16th and 17th centuries, typically designated Manoa. Manoa as El Dorado was usually marked on maps, typically on the shore of a large body of water in the Amazon jungle called Lake Parime. This only confirmed to many that the City of Gold's existence had been confirmed and was a real location to which one could make a journey.



In 1595 and 1596 Sir Walter Raleigh made attempts to reach Manoa by following one of the many old maps to El Dorado, aiming to reach Lake Parime in the highlands of Guiana. He was familiar of the account of “Juan Martinez,” recounted above. Raleigh apparently heard the story from Don Antonio de Berrio (an early governor of Venezuela who died in 1597). Raleigh's second-in-command, a sailor named Lawrence Keymis, had determined after discussions with natives in Guiana that Manoa could be reached by travelling up the Essequibo River, the largest river in Guiana and the largest river in South America between the Orinoco and the Amazon. The Essequibo River largely defines Guiana, which eventually became a Dutch colony and then a British colony and finally gained independence in the 1960s. It is the only country in South America where English is the official language.

However, Lake Parime did not exist in the interior of Guiana, nor did Manoa, the City of Gold—no matter what the maps of the time indicated. Raleigh searched for Lake Parime and Manoa and found only jungle, rivers and mountains. That he desired to establish an English outpost in Guiana was another factor in his explorations, and he was encouraged by finding some gold nuggets on a few riverbanks.

Raleigh went back to England but then returned to Guiana in 1617, this time with his son, Watt Raleigh. The father stayed at their main base of Trinidad while Watt went off to search for Manoa, but was unfortunately killed in a battle with the Spanish. Sir Walter returned to England in 1618 where King James had him executed for disobeying his orders not to come into conflict with the Spanish.

The mythical city of Manoa on Lake Parime continued to be marked on English and other maps for several hundred years. These maps usually included a link to the Essequibo River and Lake Parime. Typical of such maps were the Hondius map of 1599, the 1635 Blaeu map, the Jansson map of 1647, the 1656 Sanson map and others.

The existence of Lake Parime and the city of Manoa was finally disproven by the great German naturalist and explorer Alexander von Humboldt during his travels in South and North America from 1799 to 1804. Humboldt proposed that Lake Amucu in the North Rupununi, which had been described by a Dutch trader called Nicholas Horstmann in 1739, was the Lake Parime sought after by Raleigh. Later, German explorer Robert Hermann Schomburgk visited Lake Amucu in 1840 and noted that this area of the North Rupununi flooded at certain times of the year and linked the Amazon and Essequibo rivers as a huge swampy lake.

The Rio Negro region contains a tribe known as the Manoa and it is from these people that the major Amazon city of Manaus takes its name. British Guiana, along with Belize (British Honduras), became important Latin American colonies for the British during the 1800s and arguably Raleigh's search for El Dorado and Lake Parime helped Britain seal its claim on this territory.

With Guiana being the focus of the quest for El Dorado for centuries, the original location of the City of Gold—Colombia—became lost to history. But with the discoveries at San Agustín—starting in the late 1800s and continuing up to the 1970s—showed that a megalithic culture that mined gold and made astonishing monuments existed in the mountains of western Colombia. This area, high in the Colombian Massif, was virtually unknown to the early Spanish colonizers of Colombia. Even today the extent of this amazing civilization is just beginning to be understood.

El Dorado was said to be a source of emeralds and gold. Colombia is today the largest producer of emeralds in the world. It also produces many other gems but it has a virtual corner on the emerald market, holding an estimated 95% of the world's emerald-bearing rock. It is interesting to consider that some of the world's emeralds in ancient treasuries may have come from old trading ports on the Atlantic and Pacific coasts of Colombia. Other sources of emeralds are India, Afghanistan, Canada, Australia and Madagascar, among others.

Gold production began by at least 400 BC, according to Wikipedia and other sources. Curiously, the gold trade was said to be centered on the Pacific Coast of Colombia, rather than the Atlantic. At any rate, one would think that gold work in Colombia, and South America in general, would be much earlier than 400 BC. A date like 4000 BC would seem more correct, but since gold artifacts, such as those from Lake Guanavita or San Agustin, cannot be dated by carbon dating or other methods, we simply do not know how old many of these gold artifacts are.

Many of the artifacts are of a gold-copper alloy called tumbaga. Because of the plentiful amount of gold in Colombia and Peru, tumbaga was a common metal used to make artifacts; it was harder than copper by itself, plus other metals could be added to it. It had a fairly low melting point, lower than copper or gold on their own, and furthermore, an acid mixture such as lime juice could eat away at the outer copper surface—leaving only the gold molecules which could then be polished into a shiny gold burnish, a process known as depletion gilding.

Says Wikipedia:

The earliest examples of gold mining and goldwork have been attributed to the Tumaco people of the Pacific coast and date to around 325 BCE.

Gold would play a pivotal role in luring the Spanish conquistadores to the area during the 16th century.

Gold was considered sacred by most of the precolumbian civilizations of the area. In Muisca mythology, Gold (Chiminigagua) was considered itself a deity, and the force of creation. Copper mining was very important for the classic Quimbaya civilization, which developed the tumbaga alloy.

Much of the gold in Bogota's famous gold museum probably came from San Agustin and Tierradentro, as it would seem that the entire purpose for building these sites was the of mining of gold and other metals. Bogota's Gold Museum is one of the greatest collections in the world and probably Colombia's most important museum and tourist attraction. Gold was plentiful throughout the Andean countries, and museums in Ecuador, Peru and Bolivia also have substantial gold and tumbaga collections.

The Strange Megaliths of San Agustin

On our first day in Bogota our group visited the Gold Museum which has room after room of over 55,000 pieces of gold and other materials from all the major pre-Hispanic cultures in Colombia. Some of the gold objects were of some pretty interesting-looking people, wearing all sorts of strange headgear and clothes. Some literally looked like spacemen of some sort.



One of the rooms in the museum holds the famous display of gold “airplanes” that appear to be miniature models of winged craft, complete with a cockpit, wings and airplane-style tail. Mainstream archeologists insist that the objects must depict flying fish or birds. However, birds and fish do not have tails like these golden models—only airplanes have such tails. Could they actually depict flying craft from thousands of years

ago? Are these what some vimanas from ancient India or Sumeria looked like? Ancient astronaut theorists would say yes, but mainstream archeologists cannot believe that such advanced technology existed in the past—only our own civilization has been capable of this technology, they insist. But in 1994, German enthusiasts Peter Belting and Conrad Lubbers fashioned radio-controlled scale models of some of the planes and proved that they could fly.

Early on another morning our group set out in a private minibus from our hotel in Bogota for the long day's journey into the mountains of western Colombia. As dusk was falling on the small mountain hamlet of San Agustin our minibus pulled up to our hotel a few blocks from the main square of the small, but bustling tourist town. The next morning we visited the main museum and megalithic site and after lunch we visited some of the other sites around San Agustin. San Agustin is a UNESCO World Heritage Site so let us get some official information from that organization.

The UNESCO website (<http://whc.unesco.org/en/list/744>) says that the San Agustin Archaeological Park is the:

...largest group of religious monuments and megalithic sculptures in South America [and] stands in a wild, spectacular landscape. Gods and mythical animals are skillfully represented in styles ranging from abstract to realist. These works of art display the creativity and imagination of a northern Andean culture that flourished from the 1st to the 8th century.

The San Agustin Archaeological Park includes four separate sites, with boundaries defined so as to include the main concentrations of burial mounds with megalithic statues of the Regional Classic (1-900 AD) period. A third of the 600 known San Agustin statues and half of 40 known monumental burial mounds that are dispersed throughout the Alto Magdalena region are located inside the boundaries of the archaeological park. These 20 burial mounds include the largest and also the most elaborate examples. The "Mesitas" site, 80 ha of the park, includes 8 mounds, more than a hundred statues, and the entire core of the largest demographic and ceremonial centers—containing not only the oldest and largest tombs—Mesita A and Mesita C—sites, but also the residential remains of the elite families that ruled over their society, constructed the monuments and used them as burials for their main leaders. Thus, the park includes not only a series of separate monuments but also the vestiges of the central communities that constructed and lived beside them. In spite of the impacts of natural phenomena on the material remains, conservation actions have preserved their material integrity. Challenges remain in maintaining the integrity of such a vast area in light of pressures for extended agricultural use and growth of local communities.

The UNESCO site goes on to say:

In the pre-agricultural period, from c 3300 to c 600 BC, San Agustin was occupied by a society with a rudimentary stone technology using unretouched basalt chips; their principal food was wild fruits, but hunting cannot be ruled out.

The UNESCO site mentions gold mining at the site and that the large statues date from approximately 100 AD:

Gold working is attested by radiocarbon dating from at least the 1st Century BC, and increased substantially in the following period. Around the 1st century AD there were profound cultural changes in the San Agustin area. This was the period of the great flowering of monumental lithic art, the so-called Augustinian Culture. Links with other regions of the southwest increased, with the consequent evolution over the whole region

of societies known as Regional Classic. Population density increased markedly, and earlier settlements were reoccupied. New house sites on hilltops were also settled and occupied over long periods. The economy was still based on maize cultivation, and population pressures led to the opening up of new agricultural lands.

There was considerable social consolidation, and the concentration of substantial power in the hands of the chiefs made possible the production of gigantic works by the use of large bodies of men to carry out massive earth movements. Hundreds of elaborate stone statues were carved, some in complex relief and large in size. The huge monumental platforms, terraces, and mounds and the temple-like architecture reflect a complex system of religious and magical belief.

UNESCO defines the period from 3300 BC to 600 BC as “pre-agricultural,” but it seems doubtful that this society did not have maize, beans or other cultivated crops until 600 BC. It would seem likely that they had corn (maize), squash, beans or other agricultural crops common to Peru and Mexico at the time. Probably they had all of this, plus bananas, sweet potatoes, cassava-yucca, and even quinoa and other grains common to Peru, Ecuador and Bolivia.

In fact, it is reported that in ancient times corn (maize) was grown from Argentina to the American Southwest to Kansas and Nebraska and probably at the mound sites at Cahokia in Illinois and other sites in Indiana, Kentucky, Tennessee and Ohio. That maize was not being grown at sites in Colombia seems almost impossible. Archeologists argue about the origin of corn, much like bananas, sweet potatoes, cotton and other crops. While archeologists in Peru claim that maize was first cultivated there, archeologists in Mexico claim that maize was first grown in the highlands of central Mexico by the mysterious culture known as the Olmecs.



Corn grown in Peru can be very large, much larger than that in North America, and it seems likely that the highlands of Colombia and Ecuador were growing large crops of maize for many thousands of years. It may be that the Olmecs first domesticated maize in Mexico and spread it to South America, or perhaps it came to Mexico from South America—also with the Olmecs. The [Fuente Magna Bowl](#) at the Museum of Precious Metals in La Paz, Bolivia, indicates that the Sumerians were in Peru and Bolivia by 3000 BC. Possibly they brought maize from Mexico to Peru, or vice versa. Either way, it is likely that Colombia had maize cultivation by at least 4000 BC. Bio-

archeologists currently put the cultivation of a domesticated maize—either in Peru or Mexico—at 9,000 BC. The banana was genetically engineered into a seedless fruit about the same time (see WEX Vol. 6, No. 9).

UNESCO and mainstream archeologists maintain that the earlier megalithic mining culture of Colombia came to a sudden halt around 700 AD and that sophisticated terrace building and drainage projects, as seen at San Agustin, came to an end. Essentially, the culture underwent a slow decline until nothing was really left, some 800 years before the European explorations of rediscovery.

The mystery of these imaginative and industrious people and where they came from persists today. San Agustin is similar to and of the same level of stonework and megalithic artistry as the work of the Olmecs in Mexico and Guatemala, the stone balls of Costa Rica and the statues at Tiwanaku.

Giant granite boulders from the mountain streams, some weighing many tons, were moved to artificial mound sites and then carved into grand monuments, some as tall 21 feet (7 meters). It is



estimated that more than 500 statues are scattered over a wide area in the green hills surrounding San Agustin. Many of the statues are of fang-toothed men holding clubs or babies, while others resemble masked monsters. Many have unusual hats or helmets on. Some hold their arms over their heart and stomach in the classic “Tiki” pose. There are also sculptures depicting animals such as an eagle, frog and jaguar.

Nowhere are we told how these astonishing statues were carved, or why. We are told that these statues had magical and protective qualities and some of them were “guardians” of the monumental tombs, complete with gigantic sarcophagi, that are scattered among the hills. The effort that all this must have taken, including the huge earthworks, is considerable. Archeologists portray these people as an isolated culture that suddenly decided to put their efforts into carving gigantic statues with an unmistakable artistic flair.

The UNESCO site goes on to say that:

The Alto de los Idolos is on the right bank of the Magdalena River and the smaller Alto de las Piedras lies further north: both are in the municipality of San José de Isnos. Like the main San Agustin area, they are rich in monuments of all kinds. Much of the area is a rich archaeological landscape, with evidence of ancient tracks, field boundaries, drainage ditches and artificial platforms, as well as funerary monuments. This was a sacred land, a place of pilgrimage and ancestors worship. These hieratic guards, some more than 4 m high weighing several tonnes, are carved in blocks of tuff and volcanic rock. They protected the funeral rooms, the monolithic sarcophagus and the burial sites.

The main archaeological monuments are Las Mesitas, containing artificial mounds, terraces, funerary structures and stone statuary; the Fuente de Lavapatatas, a religious monument carved in the stone bed of a stream; and the Bosque de Las Estatuas, where there are examples of stone statues from the whole region.

A new society appeared in the region in the 7th century BC: the people cultivated maize on the flat land or gentle slopes and lived in dispersed houses near the main rivers, possibly in simple groups headed by chiefs. The extended burials were in vertical shaft tombs, with simple grave-goods. The period probably lasted until the 3rd or even the 2nd century BC.

Around the 1st century AD there were profound cultural changes in the area: this was a time of a great flowering of monumental lithic art and the so-called Agustinian Culture. Links with other regions of the south-west grew, population density increased markedly, and earlier settlements were reoccupied. New house sites on the hilltops were also settled and occupied over long periods. There was considerable social consolidation and the concentration of substantial power in the hands of the chiefs made possible the production of gigantic works: hundreds of elaborate stone statues were carved, some in complex relief and large in size. The huge monumental platforms, terraces and mounds and the temple-like architecture reflect a complex system of religious and magical belief. Some 300 enormous sculptures (divinities with threatening faces, warriors armed with clubs, round eyes and jaguars’ teeth of mythical heroes) stand in the region of Agustin in the heart of the Andes, El Huila Province.

Marveling at the many dolmens, statues and sarcophagi, I couldn't help noticing the similarity to Olmec statues and monumental works that can be found on the Gulf Coast of Mexico as well as on the Pacific Coast and in southern Mexico. The sharp features in the carving also



made me think that these statues were not bashed out with a rock hammer. It would seem that metal chisels were being used, and possibly even power tools.

The similarity of San Agustín to places like the Bada Valley in Indonesia, the Plain of Jars in Laos and even the Cham statues of central Vietnam was evident to me. These stone workers cut and moved huge blocks of granite and basalt, like the Olmecs, and were known to have metals such as bronze and iron. Was San Agustín part of a trans-oceanic trade network that included Asians, Olmecs, Africans and Phoenicians? Because of their practice of child sacrifice, the Phoenicians were known to have statuary of men holding babies—babies that were about to be consecrated to the gods.

The Road to Tierradentro

We left San Agustín early one morning and drove over the mountains to Popayan, the capital of Cauca Department. It was an all-day drive, passing through some beautiful and remote mountain country. As noted above, Popayan was founded by Spanish conquistador Sebastián de Belalcázar in 1537. It is also an area of gold mining that produced Escudo gold coins and silver Reales for the Spanish crown from 1760 through 1819.

We spent the night in Popayan's charming old town, and then our chartered bus took us back into the mountains to the curious archeological site of Tierradentro located about 40 miles (100 km) from the city.

Tierradentro ("Inner Earth") is the second-most important archaeological site in Colombia, after San Agustín, but gets far fewer visitors. The rough mountain road, much of it very muddy from the frequent rains, was along steep mountain valleys and it was clear that parts of the road would wash out from time to time. A lot of road construction was taking place at the time of our journey!

There are some statues, like those at San Agustín, but Tierradentro is mainly known for its elaborate underground tombs. So far, archaeologists have discovered about 100 of these unusual funeral temples that are cut into solid rock and painted with geometric patterns. These underground funerary temples are known as hypogea or hypogeum (singular).

These hypogea are scattered on various hills around the town with names such as Alto del Aguacate (Avocado Hill), Alto de Segovia, Alto de San Andrés, Alto del Duende and El Tablón. There are also two museums and an open-air granite statuary park.



The typical hypogeum has an entry, like a trap door, with a spiral staircase leading steeply down to the main chamber, usually 15 to 30 feet below the surface. Some of the tombs have several lesser chambers around the central chamber. Each would probably have contained a large ceramic pot in which the cremated remains of the deceased were kept. Some of these urns can be seen at the museums.

The walls of the tombs are painted with geometric, anthropomorphic and zoomorphic patterns in red,

black and white. The domed ceilings of the largest hypogea are supported by pillars that are part of the solid rock. Most of the tombs have been looted, but the museums in town still have plenty of ceramic objects and fabrics on display. There are some monumental statues as well, which archeologists admit are very similar to those at San Agustin. Indeed, were they the same culture?

The timeframe for Tierradentro is about the same as San Agustin, approximately 300 AD to 600 AD, though it seems that no really good dating has been done at Tierradentro. The rock-cut tombs would probably have been used over and over again through the centuries, and one would think that the statues in Tierradentro were made at about the same time as those in San Agustin. Indeed, Tierradentro was apparently a gold mining area in ancient times, like San Agustin. Gold artifacts have been discovered at Tierradentro and some are now at the Gold Museum in Bogota.

We spent several days in Tierradentro, visiting the museums and hiking around the hills to the tombs that were generally kept under lock and key by guards. The steps of the cut-stone spiral staircases were often quite big, making me wonder if the people were literal giants who could walk down such staircases with ease.

While mainstream archeologists think that megalithic cultures like those at San Agustin and Tierradentro were isolated peoples who, for unknown reasons, independently began carving granite boulders into elaborate, beautiful and bizarre statues. They created artificial mounds and cut tombs into solid rock and must have had some pretty large houses, as well as kilns for firing the ceramic objects and even forges for working the metals.

Statues at Tierradentro were finely made of granite, a very hard rock, and in some cases the people depicted were as bizarre as the ones in San Agustin, with large eyes and strange hats. Mainstream archeologists would likely say that stone hammers and chisels were used in the making of the statues and the rock-cut tombs, but they are so well made that I would have to say that iron chisels and even power tools were used in their manufacture.

Indeed, what appears to have happened at Tierradentro and San Agustin is that a sophisticated group of foreigners arrived in Colombia and started two mining operations in the western mountains. With sophisticated mining tools, including possibly power tools, they began extracting tons of gold from the mountain streams and nearby gold mines. When not extracting gold or copper they built large homes with farms, and industries like ceramics. And, in their spare time, they used their mining tools to carve granite boulders into statuary. This statuary probably had some sort of magical or religious purpose though in some cases it may just represent some of the lords or ladies of this extended mining camp. One large boulder by the school in the center of town had a number of drill marks on it, seemingly made by a large power tool.



The way that the statues were dressed and the unusual ways that they held their hands and arms, often with a baby or club in their hands, made me think of the Tiki statues in the Marquesas Islands and Tahiti, as well as the Kon Tiki statue at Tiwanaku in Bolivia. The Olmecs and Phoenicians also made similar statues making unusual hand and arm gestures. In ancient India such arm, hand and figure positions are known as “mudras” and every different position has a different meaning. The mysterious statues in Colombia seem to be also communicating in some way.

As we left Tierradentro after a few days I looked back at the steep mountain valleys that the road clung to. We stopped briefly at a spot where the road had collapsed and a bulldozer was pushing dirt and mud around to clear the road. Even today travel in this area is relatively difficult,

and it must have been even more difficult in ancient times. Coming by helicopter or airship would be the easiest way to arrive in Tierradentro. Maybe the gold airplanes back in Bogota were souvenirs from the ancient airports that once existed at San Agustin and Tierradentro. The strange world of ancient Colombia was one in which it seemed anything could have happened.

The Zen Is Mightier Than the Sword

—Dennis Stillings

From the early 1980s until the end of the century, strange, yet very widespread, beliefs and practices manifested in the United States and virtually throughout the world. Some of these beliefs were mostly a collective hysteria—For example, the belief that witchcraft and black magic were being practiced in daycare centers, or that people were being abducted by aliens (at least whenever the aliens took time off from busily mutilating livestock). To top it off, there was the fear that life as we knew it could end on December 31, 1999, at midnight, due to a computer glitch (Y2K). Paralleling this was a revival of interest in parapsychology in all its manifestations: precognition, psychokinesis, telepathy, and remote-viewing. Interest in alternative medicine skyrocketed. Thousands of people fire-walked across beds of 2000-degree red-hot coals, almost all without incurring injury. Several TV shows with paranormal and occult themes, such as *The X-Files*, *Twin Peaks* and *Millennium*, were very popular.

In particular, the reader might remember the widespread practice of psychic metal-bending, or “warm-forming” that was very popular during the 1980s and into the 1990s. It was claimed that strong metal bars, flatware and even brittle plastic, cast iron and ceramics could be bent into contorted shapes by simply stroking an object and willing it to bend. The central figure of the metal-bending craze was Uri Geller, who demonstrated this ability on several TV shows and who was the subject of many scientifically-controlled experiments attempting to verify the reality of the phenomenon.

Interest in psychic metal-bending also gave rise to so-called “PK (psychokinesis) parties.” Hundreds of such events took place throughout the United States, and hundreds more around the world. One of the leading theoreticians on the subject, an engineer working at McDonnell-Douglas named Jack Houck, conducted over 200 such parties. Among other things, he was addressing concerns that it might be possible for humans, when in a highly emotional state, to cause dangerous glitches in highly sensitive electronic equipment, such as exists in modern airplanes.

Psychic metal-bending may have a long history. In Mark 5:2-4 (KJV), we read:

And when Jesus was come out of the ship, immediately there met him out of the tombs a man with an unclean spirit, who had his dwelling among the tombs; and no man could bind him, no, not with chains: Because that he had been often bound with fetters and chains, and the chains had been plucked asunder by him, and the fetters broken in pieces: neither could any man tame him.

Certain old initiation rites in the Far East involved demonstrating the ability to bend metal psychically. An example of this may be found in the October 1935 *National Geographic*. According to the account given by Joseph F. Rock in “Sungmas, the Living Oracles of the Tibetan Church,” Sungma Balung chü dje, “when possessed by the god Chechin,” appeared to acquire “superhuman strength.” Sungma Balung chü dje instantly wound into coils a sword made of Mongolian steel. The sword could barely be bent by a strong man. It was given to the leader of the National

Geographic Society's Yunnan Expedition. I have made extensive inquiries as to the present location of this remarkable artifact, but could come up with nothing.



© National Geographic Society

Autochrome Lumière by Charles Martin

WITH BARE HANDS THE ORACLE TWISTED THIS SWORD OF MONGOLIAN STEEL

Sungma Balung chü dje (opposite page) seemed to have superhuman strength when possessed by Chechin. In an instant he wound into coils the weapon which a normally strong man could hardly bend. He gave it to the leader of The National Geographic Society's Yunnan Expedition.

My guess is that this sword might be found in one of the Smithsonian's warehouses, perhaps in the very one in which the Ark of the Covenant is stored.

WISE Adds 25 More Full-Text Periodical Titles to Its Digital Library, Total Now at 307

By John H. Reed, M.D.

The [WISE Digital Library \(click here\)](#) is continuing to grow at a very fast pace, and 25 more full-text periodical titles, and/or links to them, have recently been added, bringing the total to 307 different periodical title collections. The full list of these newly added periodical titles are at the bottom of this article, categorized by the library collection they have been placed into. In addition, each journal has a description and a direct link to the full text issues.

This is the largest collection of periodicals in the world on the specialized subjects that these periodicals cover, which includes many older, pre-Internet periodicals that are often physically available at only a few libraries in the world. These digitized periodicals cover the fields of scientific anomalies, alternative medicine and indigenous medicine therapies, consciousness and parapsychology, alternative energy, historical mysteries, and other unexplained phenomena. They include journals, magazines, organization newsletters, and other types of periodicals, many of which are very rare.

If anyone else knows of other periodicals that are freely available on the above subjects, but are not yet in the WISE Digital Library, please let us know, and WISE will add them to the library. In additions to many defunct periodicals, we believe that there are probably many other online periodicals being published on the above subjects which we are unaware of, some of which you may be publishing yourself.

So if you would like to give your periodical or organization exposure to a large worldwide audience, please let us know, and we will add your periodical to the WISE Digital Library for all to see. We now have more than 10,000 members and research associates worldwide, so you would be able to get good exposure to people specifically interested in the above subjects.

Moreover, if your periodical is defunct or has otherwise discontinued publishing, even 50 or more years ago, we can help “resurrect” it and put it feely online for the researchers of the world to use. It may actually get more exposure online now than it did when it was in physical publication. So let us know if you would like to resurrect your

periodical, or even the periodical published by someone else. We will help secure any necessary copyright permissions that may be required.

One thing of importance to note is that WISE does not want to duplicate other's efforts, nor do we want others to duplicate our efforts. So please continue to let us know of other websites with digitized periodicals, and we will just link to them, and they can link to the WISE Digital Library listings. And tell others about the WISE Digital Library so that they can avoid duplication of effort as well. If we all work together, we can create a huge, valuable resource for researchers worldwide.

Also, if you check for a periodical and find that it is not available in our library, please write to me at: joreed43@gmail.com and let me know, and tell me if you know where it is available online anywhere. Or if you have physical copies of that periodical, please let us know and we will xerox and/or digitize them for you. But if you have a copier or scanner at home, work, or elsewhere that you can use, you could help the entire world of researchers if you would copy or scan the physical copies you have and send them to us so we can make them freely available to the world.

Thank for again, because it is you, our dedicated WISE directors, research scientists and associates who have made the WISE Digital Library possible. All correspondence should go to John H. Reed, M.D.: joreed43@gmail.com

The following journals and other periodicals have recently been added to the WISE Digital Library. The subject in parentheses indicates the subject category in the WISE Digital Library where that periodical is to be found:

New Additions of Full Text Periodicals (25):

[The full WISE Digital Library of all 307 full text periodicals is at this location: [http://wisewiki.org/tiki-index.php?page=WISE+Digital+Library+\(WDL\)](http://wisewiki.org/tiki-index.php?page=WISE+Digital+Library+(WDL))]

Biomedical Journals and Periodicals - Library Additions

American Journal of Electrotherapeutics and Radiology

The American Journal of Electrotherapeutics and Radiology (ISSN: ?) was a hardcopy periodical published in New York, NY, by the American Electrotherapeutic Association, from 1916-1926. Its previous title was Journal of Advanced Therapeutics, and continued the numbering of that journal. This periodical focused on all aspects of electrotherapeutics and the use of electricity for the treatment of medical disorders, including microbial diseases, as well as treatment by ionizing radiation. It began with Volume 34 (1916) and continued to be published through Volume 44 (1926), when its named was

changed again to Physical Therapeutics. Due to copyright restrictions only Volumes 34 (1916) through Volume 40 (1922) are made freely available at the following website: <http://catalog.hathitrust.org/Record/000638392?type%5B%5D=title&lookfor%5B%5D=%22American%20journal%20of%20electrotherapeutics%20and%20radiology%22&ft=>

Aromatherapy on the Record

Aromatherapy on the Record (ISSN: ?) was a hardcopy periodical published in Waterloo, Ontario, Canada, by the Canadian Federation of Aromatherapists (CFA) from 2001-2012. This periodical focused on all aspects of aromatherapy and the activities of the CFA. It began with Volume 1, No. 1 (Fall, 2011) and continued to be published through issue Volume 5 (Fall, 2012). It is not known if any issues were published after No. 5. Issues 1-5 are digitized, and along with two issues of the CFA Newsletter, are made freely available at the following website: <http://cfacanada.com/newsletter/>

AYU - The International Quarterly Journal of Research in Ayurveda

AYU - The International Quarterly Journal of Research in Ayurveda (ISSN: 0974-8520) is a quarterly hardcopy and online periodical currently being published by the Institute for Post Graduate Teaching and Research in Ayurveda at the Gujarat Ayurved University in Jamagar, India. This periodical focuses on all aspects of Ayurvedic and traditional Indian medicine. It began with Volume 1, No. 1 in 1980 and continues to be published through the present. All issues from Vol 27, No. 1 (January-March, 2006) through the present are freely available at: <http://www.ayujournal.org/backissues.asp>

Bacteriophage

Bacteriophage (ISSN: 2159-7081) is an online, peer reviewed journal currently being published by Landes Bioscience, Austin, Texas. This periodical focuses on all aspects of bacteriophages, including the use of phage therapy to treat bacterial infections. It began with Volume 1, No. 1 in 2011 and continues to be published through the present. All issues from Volume 1, No. 1 are freely available at the following website: <http://www.tandfonline.com/loi/kbac20#.VdEPFbR9ZK1>

Cincinnati Medical Advance

The Cincinnati Medical Advance (ISSN: ?) was a hardcopy periodical published in Batavia, Illinois, by J.E. Forrest, from 1874-1914. This periodical focused on all aspects of homeopathy and related subjects. It began with Volume 1, No. 1 (1874) and continued to be published through Volume 52 (1914). All of the above volumes are digitized, and made freely available at the following website: <http://catalog.hathitrust.org/Record/000550939>

Hering quarterly, The - Devoted to Hahnemannian Homeopathy

The Hering Quarterly, Devoted to Hahnemannian Homeopathy (ISSN: ?) was a hardcopy periodical published in Batavia, Illinois, by J.E. Forrest from 1908-1910. This periodical focused on all aspects of homeopathy and related subjects. It began with Volume 1, No. 1 (May, 1908) and continued to be published through Volume 2, No. 2 (August, 1910). All of the above volumes are digitized, and made freely available at the following website: <http://catalog.hathitrust.org/Record/000535610>

Homeopathic World

Homeopathic World (ISSN: ?) was a hardcopy periodical published in London, England, by the Homeopathic Publishing Company from 1866-1932. This periodical focused on all aspects of homeopathy and related subjects. It began with Volume 1, No. 1 (1866) and continued to be published through 1932. Issues for Volume 1 (1866) through Volume 56 (1921) are digitized, and made freely available at the following website: <http://catalog.hathitrust.org/Record/100113321>

International Journal of Pharmaceutical and Biological Archive

International Journal of Pharmaceutical and Biological Archive (ISSN: 0976-3333) is an online, peer reviewed journal currently being published by the Mandasaur Institute of Pharmacy, Mandasaur, Madhya Pradesh, India. This periodical focuses on all aspects of medicinal plants, pharmacognosy, and Ayurvedic medicine. It began with Volume 1, No. 1 in 2010 and continues to be published through the present. All issues from Volume 1, No. 1 are freely available at the following website: <http://www.ijpba.info/ijpba/index.php/ijpba/issue/archive>

International Journal of Phytomedicine

International Journal of Phytomedicine (ISSN: 0975-0185) is an online, peer reviewed journal currently being published by Advanced Research Journals in India. This periodical focuses on all aspects of medicinal herbs, herbal formulations, phytopharmacy, and related subjects. It began with Volume 1, No. 1 in 2009 and continues to be published through the present. All issues from Volume 1, No. 1 are freely available at the following website: <http://arjournals.org/index.php/ijpm/issue/archive>

Journal of Advanced Therapeutics

The Journal of Advanced Therapeutics (ISSN: ?) was a hardcopy periodical published in New York, NY, by the American Electrotherapeutic Association, from 1902-1915. Its previous title was Journal of Electrotherapeutics, and continued the numbering of that journal. This periodical focused on all aspects of electrotherapeutics and the use of electricity for the treatment of medical disorders, including microbial diseases. It began with Volume 20 (1902) and continued to be published through Volume 33 (1915), when its name was changed again to The American Journal of Electrotherapeutics and Radiology. Volumes 20-33 are digitized, and made freely available at the following website: <http://catalog.hathitrust.org/Record/000638395?type%5B%5D=title&lookfor%5B%5D=%22Journal%20of%20advanced%20therapeutics%22&ft=>

Journal of Ayurveda and Holistic Medicine

Journal of Ayurveda and Holistic Medicine (ISSN: 0975-0185) is an online, peer reviewed journal currently being published by Atreya Ayurveda Publications in Joshigalli, India. This periodical focuses on all aspects of Ayurveda, naturopathy, yoga, medicinal plant sciences, and related subjects. It began with Volume 1, No. 1 in 2013 and continues to be published through the present. All issues from Volume 1, No. 1 are freely available at the following website: <http://jahm.in/index.php/JAHM/issue/archive>

Journal of Electrotherapeutics

The Journal of Electrotherapeutics (ISSN: ?) was a hardcopy periodical published in New York, NY, by the American Electrotherapeutic Association, from 1883-1901. This periodical focused on all aspects of electrotherapeutics and the use of electricity for the treatment of medical disorders and microbial diseases. It began with Volume 1, No. 1 (1883) and continued to be published through Volume 19 (1901), when its name was changed to The Journal of Advanced Therapeutics. Volumes 10-19 of The Journal of Electrotherapeutics are digitized, and made freely available at the following website: <http://catalog.hathitrust.org/Record/000638397>

Zeitschrift für Electrotherapie und ärztliche Electrotechnik (Journal of Electrotherapy and Medical Electrical Engineering)

Zeitschrift für Electrotherapie und ärztliche Electrotechnik (Journal of Electrotherapy and Medical Electrical Engineering) (ISSN: ?) was a hardcopy periodical published in Koblenz, Germany, from 1899-1906, under varying, but similar titles. This periodical focused on all aspects of electrotherapeutics and the use of electricity for the treatment of medical disorders and microbial diseases. It began with Volume 1, No. 1 (1899) and continued to be published through Volume 8 (1906). Issues for Volume 1-8 are digitized, and made freely available at the following websites:

Vol. 1-3: <http://catalog.hathitrust.org/Record/100413101>

Vol. 4-

8: <http://catalog.hathitrust.org/Record/100413131?type%5B%5D=title&lookfor%5B%5D=%22Zeitschrift%20f%C3%BCr%20Elektrotherapie%20und%20physikalische%20Heilmethoden%22&ft=>

Consciousness and Parapsychology Journals and Periodicals - Library Additions

American Spiritual Magazine

American Spiritual Magazine (ISSN: ?) was a monthly hardcopy periodical published in Memphis, Tennessee, by the Baptist Publishing Society from 1875-1877. This periodical focused on all aspects of spiritualism, spirit materializations, spirit communication, and related subjects. It began with Volume 1, No. 1 (January, 1875) and continued to be published through Volume 3, No. 9 (September, 1877), when it ceased publication. All issues from Volume 1, No. 1 have been digitized and are made freely available at the website of the International Association for the Preservation of Spiritualist and Occult Periodicals (IAPSOP), below. Additional valuable publishing information is also available about this periodical at the IAPSOP website.

http://www.iapsop.com/archive/materials/spiritual_magazine_memphis/

L'Hermès, Journal du Magnétisme Animale

L'Hermès, Journal du Magnétisme Animale (ISSN: ?) was a hardcopy periodical published in Paris, France, by the Societe de Medicine de la Faculte de Paris from 1826-1829. This periodical focused on all aspects of mesmerism, hypnotism, animal magnetism, and related subjects. It began with Volume 1, No. 1 (1826) and continued to be published through 1829. It is not known if any issues were published after 1829. All of the above volumes are digitized, and made freely available at the following website: <http://catalog.hathitrust.org/Record/000050642>

L'Initiation : Revue Philosophique Independante des Hautes Etudes

L'Initiation : Revue Philosophique Independante des Hautes Etudes (ISSN: ?) was a hardcopy periodical published in Paris, France, from 1888-1903. This periodical focused on all aspects of occultism, hypnotism, theosophy, Freemasonry, and related subjects. It began with Volume 1, No. 1 (1888) and continued to be published through Volume 58 (1903). It is not known if any issues were published after Volume 3. Volumes 1-58 are digitized, and made freely available at the following website: <http://catalog.hathitrust.org/Record/012446741>

Occidental Mystic and Occult

Occidental Mystic and Occult (ISSN: ?) was a hardcopy periodical published variously in San Francisco, CA, Denver, CO, and then Los Angeles, CA, by the Occidental Mystic & Occult Publishing Co. from 1907-1910. This periodical focused on all aspects of occultism, mysticism, and related subjects . It began with Volume 1, No. 1 (October, 1907) and continued to be published through Volume 3, No. 9 (June, 2010). All issues from Volume 1, No. 1 have been digitized and are made freely available at the website of the International Association for the Preservation of Spiritualist and Occult Periodicals (IAPSOP), below. Additional valuable publishing information is also available about this periodical at the IAPSOP website. http://www.iapsop.com/archive/materials/occidental_mystic_and_occult/

Occult Review (London, UK)

Occult Review (ISSN: ?) was a monthly hardcopy periodical published in London, England, by William Rider and Son from 1905-1951. This periodical focused on all aspects of occultism, parapsychology, psychic sciences, and related subjects . It began with Volume 1, No. 1 (January, 1905) and continued to be published through 1951, when it ceased publication. All issues from Volume 1, No. 1 through Volume 36, No. 6 (December, 1922) have been digitized and are made freely available at the website of the International Association for the Preservation of Spiritualist and Occult Periodicals (IAPSOP), below. Additional valuable publishing information is also available about this periodical at the IAPSOP website. http://www.iapsop.com/archive/materials/occult_review/

Quest, The

The Quest (ISSN: ?) was a hardcopy periodical published in London, England, by John M. Watkins from 1909-1922. This periodical focused on all aspects of occultism, mysticism, and related subjects. It began with Volume 1, No. 1 (October, 1909) and continued to be published through Volume 13 (1922). It is not known if any issues were published after 1922. All of the above volumes are digitized, and made freely available at the following website: <http://catalog.hathitrust.org/Record/100584338>

[Energy - Alternative and New Energy Journals and Periodicals – Library Additions](#)

Fusion Facts

Fusion Facts (1051-8738) was a hardcopy periodical published in Salt Lake City, Utah, by the Fusion Information Center from 1993- 1999. This periodical focused on low energy nuclear reactions (LENR), cold fusion, and related subjects. It began with Volume 1, No. 1 (July, 1989) and continued to be published through issue Volume 8, No. 6 (December, 1996) Beginning in 1997, it was incorporated into

the journal, Journal of New Energy . All known issues of Fusion Facts are digitized and made freely available at the following website: <http://newenergytimes.com/v2/archives/fic/facts.shtml>

Journal of New Energy

Journal of New Energy (1086-8259) was a hardcopy periodical published in Salt Lake City, Utah, by the Fusion Information Center from 1996- 1999. This periodical focused on low energy nuclear reactions (LENR), cold fusion, high-density changer cluster technology, high-efficiency motors or generators, other new energy devices, and related subjects. It began with Volume 1, No. 1 (January, 1996) and continued to be published through issue Volume 4, No. 1 (Summer, 1999). All known issues of are digitized and made freely available at the following website: <http://newenergytimes.com/v2/archives/fic/jne.shtml>

New Energy News

New Energy News (1075-0045) was a hardcopy periodical published in Salt Lake City, Utah, by the Institute for New Energy from 1993- 1999. This periodical focused on all types of new forms of energy, including hydrogen energy, zero point energy, low energy nuclear reactions (LENR), water as fuel, and related subjects. It began with Volume 1, No. 1 (May, 1993) and continued to be published through at least issue Volume 6, No. 11 (September, 1999) It is not know if subsequent issues were ever published. All known issues are digitized and freely available at the following website: <http://newenergytimes.com/v2/archives/fic/nen.shtml>

Scientific Anomalies in the Physical Sciences Library Additions

Journal of the Alchemical Society, The

The Journal of the Alchemical Society (ISSN: ?) was a hardcopy periodical published in London, England, by the Alchemy Society from 1913-1915. This periodical focused on all aspects of alchemy and the history of chemistry. It began with Volume 1, No. 1 (May, 1913) and continued to be published through Volume 3 (1915). It is not known if any issues were published after Volume 3. Volumes 1-3 are digitized, and made freely available at the following website: <http://catalog.hathitrust.org/Record/012368834>

Water Journal

Water Journal (ISSN: 2155-8434) is an online, peer reviewed journal, edited by Dr. Gerald Pollack of the University of Washington, Seattle, WA. This periodical focuses on the physics, chemistry, and biology of water, including the structure of water, the fourth phase of water, and other unusual aspects of water. It began with Volume 1 in July, 2009 and continues to be published. All issues from Volume 1 through the present are freely available at the following website: <http://www.waterjournal.org/>

Yggdrasil: The Journal of Paraphysics

Yggdrasil: The Journal of Paraphysics (ISSN: ?) was a hardcopy periodical edited and published by physicist, Dr. James Beichler, from 1996-2007. This periodical focused on all aspects of paraphysics, the physical aspects of parapsychology, and related subjects. It began with Volume 1, No. 1 (Winter, 1996) and continued to be published through Volume 4, No.1 (Winter, 2007). It is not known if any issues were published after Volume 4, No.1. All of the above volumes are digitized, and made freely available at the following website: <http://www.neurocosmology.net/yggdrasil>

Social Science Journals and Periodicals Library Additions

At the Edge

At the Edge (ISSN: ?) was a hardcopy periodical published and edited in the United Kingdom by Robert Trubshawe from 1996- 1998. This periodical focused on folklore, mythology, legends, archaeology, and archeoastronomy. It began with Volume 1, No. 1 (March, 1996) and continued to be published through at least issue No. 10 (June, 1998) It is not know if subsequent issues were ever published. Issues 1-10 are digitized and freely available at the following website: <http://www.indigogroup.co.uk/edge/backiss.htm>

WISE-Hong Kong Inaugural Opening Event – Great Success!

The Hong Kong Branch of the World Institute for Scientific Exploration (WISE-Hong Kong), headed by Dr. Albert So, held its inaugural ceremony event on September 9,



2015, with great success. A large number of people attended, attracted by theme of the event, which was about the physics behind the movie [Interstellar](#). This acclaimed movie, starring Matthew McConaughey, Anne Hathaway, Jessica Chastain, and Michael Caine, was released in 2014, and dealt with the futuristic science and technology concepts of time warps, worm holes, time travel, and the control of gravity.

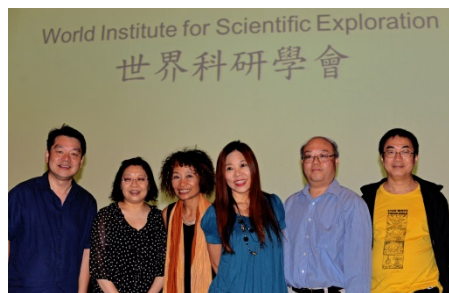

This event was organized by Dr. So, Jacqueline Lee, who is the Executive Vice Chair of WISE-Hong Kong, and Miss Y.Y. Chan, a special assistant to Jacqueline and Dr. So. In addition, Moon Fong, who is Honorary Vice Chair of WISE-Hong Kong and Keeto Lam, another Honorary Vice Chair of WISE Hong Kong, helped to make this inaugural event a great success.

The event began with introductions and welcoming remarks via pre-recorded videos by



John H. Reed, M.D., President of the World Institute for Scientific Exploration (WISE), and Vice-President of WISE, Dr. Dominic Surel. Their videos are part of the welcoming remarks that were recorded and uploaded to YouTube, and may be seen at the 6.07 minute point (Dr. Reed) and the 10.05 minute point (Dr. Surel). <https://youtu.be/E7Y3qtdV8VI>



The featured speaker was Dr. Albert So, who, besides being Director of WISE-Hong Kong, is a professor at Hong Kong University. Dr. So fascinated the crowd with descriptions on how gravity control, time travel, and related concepts depicted in the movie **Interstellar**, are no longer just ideas of science fiction, but are being actively investigated by prominent

physicists and researchers in the US, China, and elsewhere, with the goal of developing devices and methods to achieve these futuristic capabilities.

One of the most prominent of these physicists is [Dr. Kip Thorne](#), professor emeritus of the world renowned California Institute of Technology. His scientific expertise centers on the nature of space, time, and gravity, but he is perhaps best known for his controversial theory that wormholes can conceivably be used for time travel. It was Dr. Thorne's work that originally inspired the [Interstellar](#) movie, of which he was an executive producer and also acted as scientific consultant.

Dr. So's presentation generated a great deal of interest among the attendees, especially among the many Hong Kong students who attended this event, and a lively discussion followed the formal presentations. Because of the success of this event, other seminars are being planned, and it is hoped that with the aid of film clips, animation, and other modern media, more young people will develop an interest in this futuristic research, and help bring this technology to reality.

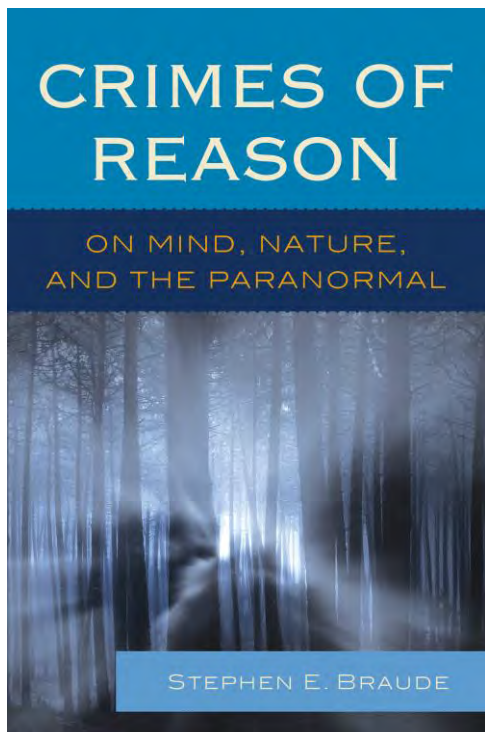

Crimes of Reason

On Mind, Nature, and the Paranormal

BY STEPHEN E. BRAUDE

ABOUT THE BOOK:

Crimes of Reason brings together expanded and updated versions of some of Braude's best previously published essays, along with new essays written specifically for this book. Although the essays deal with a variety of topics, they all hover around a set of interrelated general themes. These are: the poverty of mechanistic theories in the behavioral and life sciences, the nature of psychological explanation and (at least within the halls of the Academy) the unappreciated strategies required to understand behavior, the nature of dissociation, and the nature and limits of human abilities. Braude's targets include memory trace theory, inner-cause theories of human behavior generally, Sheldrake's theory of morphogenetic fields, widespread but simplistic views on the nature of human abilities, multiple personality and moral responsibility, the efficacy of prayer, and the shoddy tactics often used to discredit research on dissociation and parapsychology. Although the topics are often abstract and the issues deep, their treatment in this book is accessible, and the tone of the book is both light and occasionally combative.

PRAISE FOR THE AUTHOR:

Stephen Braude is a professional philosopher and well-established author both of books and articles who is particularly noted for two things. One is for his work in certain Borderland areas in which topics within philosophy, psychology, parapsychology and psychiatry meet, overlap and interact (or should interact). The other is for the clarity and pithiness of expression with which he handles abstruse and difficult issues. He has a gift for analogies, often amusing ones, which cut through layers of nonsense (often pretentious nonsense loaded with jargon) and expose the nub of a question.

— Alan Gauld, University of Nottingham

Stephen Braude is unique among those evaluating the evidence for an after-life in that he manages to combine a sympathetic consideration of favorable cases with an honest, penetrating philosophical critique of them.

— Richard M. Gale, University of Pittsburgh

ABOUT THE AUTHOR:

Stephen E. Braude is an [American philosopher](#) and [parapsychologist](#). He is a past president of the [Parapsychological Association](#), Editor-in-Chief of the [Journal of Scientific Exploration](#), and an Emeritus professor of philosophy at the [University of Maryland, Baltimore County](#).

2014 • 200 pages • Cloth ISBN **9781442211384** • List Price **\$70.00** • Discount price **\$49.00**

Rowman & Littlefield Publishing Group offers special discounts for bulk purchases in the United States by corporations, institutions, and other organizations.

For more information, please contact Nancy Hofmann in the Special Sales Department at 301-459-3366 x 5605

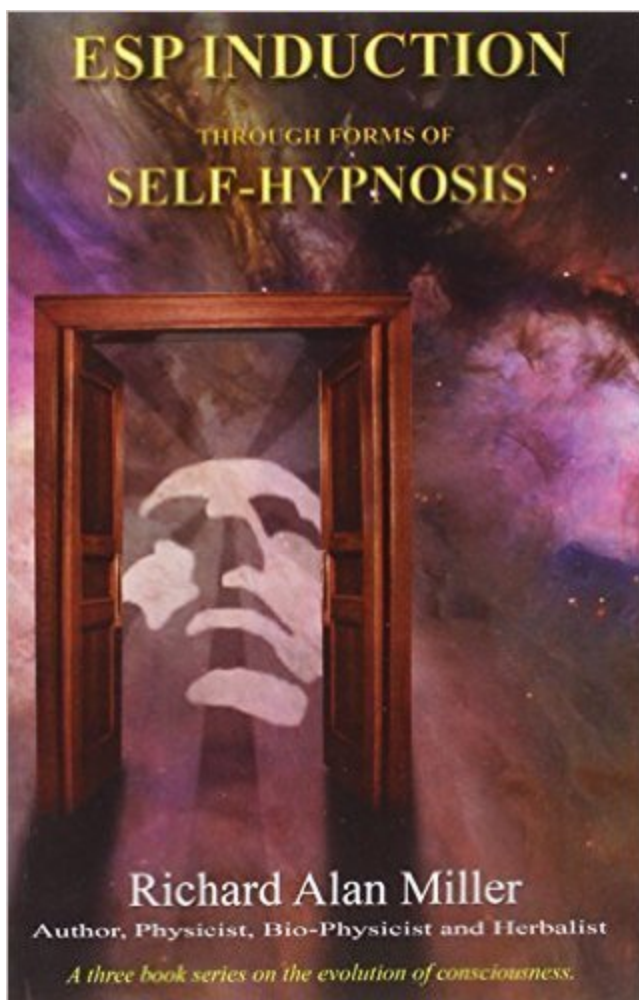

ESP INDUCTION THROUGH FORMS OF SELF-HYPNOSIS

by Richard Alan Miller, Ph.D.

Earthpulse Press, Alaska, USA, 2009

6x9"; delux color soft cover; black and white interior;
214 pages; illustrated.

ISBN 978-1-890693-30-5

Available: <http://www.earthpulse.com/src/product.asp?productid=222>

This amazing book is the first book in a three book series written by Dr. Richard Alan Miller — Toward the Evolution of Consciousness, and is a "how to" book intended to increase a person's intuition and extra sensory perception (ESP) and sixth sense. The protocols identified here have been tested and found reliable in increasing a person's intuition ability by up to 400% above an individuals beginning levels. The book introduces basic information on self-hypnosis as a tool for enhancing our latent human potentials or, as they are referred to in some military literature, "our anomalous human potentials", previously called ESP.

The book contains basic testing methods both before and after following the techniques described in these pages, so a measure of progress can be determined. The approach is simple and effective as a beginning point for those individuals with a true desire to recognize and develop their higher states of awareness.

This is the introduction to the tools for transformation and the possibilities that are emerging in this century – the century of the brain. Many scientists believe that the next evolution of human beings will be the awakening to our extrasensory capacities. If this is true, it will require a fundamental reordering of the way we see the world and our responsibilities as created human beings.

The awakening of our own possibilities is a step in this direction. There are many paths to this knowledge and this book reveals one that can easily be followed by anyone.

Author and researcher Dr. Richard Alan Miller has a depth of knowledge and experience in Psychology, Physics, and Metaphysics. He began working in the secret world of Navy Intelligence (Seal Corp. and then Mankind Research Unlimited (MRU)) in the late 1960s, and has amazing experiences and conclusions to share.

Atlin - Knowing I Am

by Dale Pond

A few years ago, a project was undertaken to create a machine to generate mechanical power that would produce useable [electricity](#) and drive machinery. This machine had been originally invented and built in the 1880s and did indeed generate



mechanical power. The team, assembled to recreate this device, thought they could duplicate this instrument using modern technology. As innocent as this goal was - things turned out rather differently. The machine was built in a surprisingly short time. Did it successfully generate power? Not in the expected way, but in a way so surprising as to be near unbelievable.

This is the story of [Atlin](#) and the people who built her, how the [dynamosphere](#) was built, when, where, how and who. It is a

personal account of the historical backgrounds, events and people by [Dale Pond](#). This book includes extensive review of construction, operation, experiences, and findings on [heart](#), health, [Consciousness](#) and connections between [Mind and Matter](#). 6" x 9" 172 pages with photos, references, bibliography and glossary. To **Purchase this book, click:** [Atlin - Knowing I Am](#)

First Message from Atlin

via [Dawn Stranges](#)

"Dear ones, just as each physical object rests upon a base, so each being and energy calls "home" that [signature](#) energy profile

that is "them". The *signature* energy picture of elements, for instance, have been documented in spectography. Mixtures can be assayed by this method to analyze their elemental components. And, so it is with beings and their energetic pictures of *consciousness*. When one has developed attuned and matured *spiritual sensory organs*, one can perceive much."

"Another paradox to address is this: *Spiritual attunement* and development create acuity, and such a state is a reflection of simplified field patterns, not more complex ones. This explains why animals, "developmentally disabled" people, children, and natural *gaiaic materials* are sometimes quicker to perceive and understand energy events and *consciousness* than the longsuffering seekers. This relates to you, dear friends in that by adopting a predominant *consciousness* as *Love* within your *soul* character, you create more cohesive and stronger *spiritual* capabilities; more *happiness* and contentment. My wish for you is that this be strong for each of you. As this happens, increased clarity results and your energy profile changes."

"When one's predominant energy profile depicts the beautiful *Love consciousness*, one builds a broad base upon which fluid interchange becomes possible with the Universe and its many nurturing forces. Do you see that if you are more and more Loving, you will feed your own *soul*, the souls of others, mine and all? In addition, you will be able to provide a broad and sturdy base upon which may rest mighty structures of *wisdom* and understanding, and subsequent good works. Such is necessary for the work you have undertaken."

"I give you my assistance, through your contact with my essence, in increasing your Loving state. Mighty and wondrous consequences await you. What you must do is face your fears and *transmute* them one by one. This is not so difficult when you have friends in high places who wish to help! Peace and *Love* to you all." - [ATLIN](#) (1/27/96)

Testimonial

Hi Dale,

"I am just re-reading the Atlin Story. I have only reached page

20, and I am saying to myself, "have you actually READ this book before?" It is as if your words are completely new. Looking at the near miraculous nature of the birth of [Atlin](#), and to think that you are going through the same processes, albeit with a much greater awareness of the energies involved, makes me feel totally humbled by your devotion to a project that is consuming great swathes of your most valuable time, and by your prolific talents. A price tag cannot be put on this embryonic Sun fashioned by you. In your endeavors you are forging two new understandings, both of colossal importance for our time. The resurrection of Keely's Science, and the resurrection of the use of the multidimensional capabilities of the Human Mind. The two needed to go hand in hand, a sympathetic double revelation." Peacedruthers

Purchase this book [Atlin - Knowing I Am](#)

Boost Your Immunity

PREMIER Junior

**Hand Held Tesla Coil
High Voltage Device**
generates electronic
antioxidants up to 45 kV

1. *Relieves pain quickly by
treating free radicals locally*
2. *Strengthens the body's im-
mune system by increasing
Transmembrane Potential*

"Nerve damage for years....several operations, tons of pain killers. I experience relief immediately. My doctor bought one as well." -Elliott

"I had gum infection from surgery.... antibiotic resistant. In just over 2 weeks, its now gone, totally unexpected" -Robert D.



Photonic
Rejuvenation
Energizing
Machine &
Immunizing
Electrification
Radiator

**Starts
at
\$495**

800-295-7674 301-220-0440

BioenergyDevice.org

Heal in Half the Time with PEMF



EM Pulser – New and Improved Version of Dr. Gordon's



Including a 30-page *User Manual*
with all of Dr. Gordon's original
articles

Activate Heat
Shock Protein 70
the key to tissue
repair - Dr. Gordon
DVD free w/order



With **FREE**
battery
recharger

Rechargeable Internal Battery, More Powerful Pulse, Faster Pulse Rate, Bigger Coil, but still with the SAME Nanosecond Risetim!

OsteoPad.org

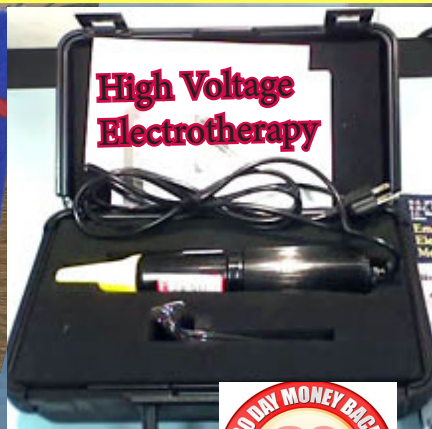

Increase Bone Density While You Sleep

BioenergyDevice.org



Integrity Research Institute 800-295-7674